



WaterFurnace® 
Smarter from the Ground Up™

Specification Catalog

7 Series
700A11

Geothermal Heat Pump - 50Hz
009 - 015 kW (variable speed)

Table of Contents

- Model Nomenclature 5
- EN 14511 Performance Ratings 6
- 7 Series Design Features 7
- The Aurora™ Advanced VS Control System 11
- Operation Logic 20
- Water Quality 21
- Dimensional Data 22
- Physical Data 26
- Auxiliary Heat Ratings 27
- Auxiliary Heat Electrical Data 27
- Electrical Data 28
- Blower Performance Data 29
- Reference Calculations 30
- Legend 30
- Operating Limits 30
- Antifreeze Corrections 31
- Performance Notes 31
- Pressure Drop 32
- Correction Factor Tables 33
- Performance Data 34
- Wiring Schematics 40
- Engineering Guide Specifications 44
- Revision Guide 47

7 Series

700A11 Geothermal Heat Pump With Variable Speed Compressor Technology



The WaterFurnace 7 Series is a new level of innovation and performance with all new advanced controls mated with variable speed compressor technology. The 7 Series is available in 3 variable speed capacity sizes (009 to 015 kW) with Danfoss Variable Speed Compressors. These units feature high efficiency permanent magnet compressors coupled with high efficiency electronic drives to allow capacity ranges between 20 and 100%. These 7 Series units utilize ozone-safe R-410A refrigerant to meet the most stringent EPA requirements. Exclusive FormiShield Plus double coated air coils add durability and longer life. ECM blower motors bridge the gap of high efficiency ECM capability with great value. ECM blowers are used to increase comfort, efficiency, and airflow flexibility.

A new sophisticated Aurora™ Control system is modular and designed for the most demanding application. The Aurora Control features a microprocessor control to sequence all components during operation for optimum performance. Plus, it provides easy-to-use troubleshooting features with fault lights, on-board diagnostics, and a hand held Aurora Interface Diagnostic (AID) Tool. The Aurora system includes advanced loop and hot water generator pump control, as well as service, performance, and energy monitoring sensor kit capability. A swing-out control box provides serviceability. Unit configurations include vertical top, bottom, or rear discharge (left or right return) and horizontal units with left or right return and side or end discharge. Heavy-gauge metal cabinets are fully insulated and coated with an attractive and durable gray paint for long lasting protection. The cabinet's rounded front corners, charcoal wave styling element, and 7 Series nameplate add a touch of elegance to the unit.

7 Series products are performance-tested to the EN14511 standard and tested in an ISO 17025 accredited testing lab.

As a leader in the industry, WaterFurnace is dedicated to innovation, quality, and customer satisfaction. In fact, every unit built is exposed to a wide range of quality control procedures throughout the assembly process and is then subjected to a rigorous battery of computerized run tests to certify that it meets or exceeds performance standards for efficiency and safety, and will perform flawlessly at startup. As further affirmation of our quality standards, each unit carries our exclusive Quality Assurance emblem, signed by the final test technician.



WaterFurnace International's corporate headquarters and ISO 9001:2008 certified manufacturing facility are both located in Fort Wayne, IN. A scenic 12,141m² pond located in front of the building serves as our geothermal heating and cooling source to comfort-condition our 10,219m² of manufacturing and office space. As a pioneer, and now a leader in the industry, the team of WaterFurnace engineers, customer support staff, and skilled assembly technicians is dedicated to providing the finest comfort systems available.

By choosing or specifying WaterFurnace 7 Series products, you can be assured that your customer is investing in the ultimate comfort system and peace of mind for many years to come.

Model Nomenclature

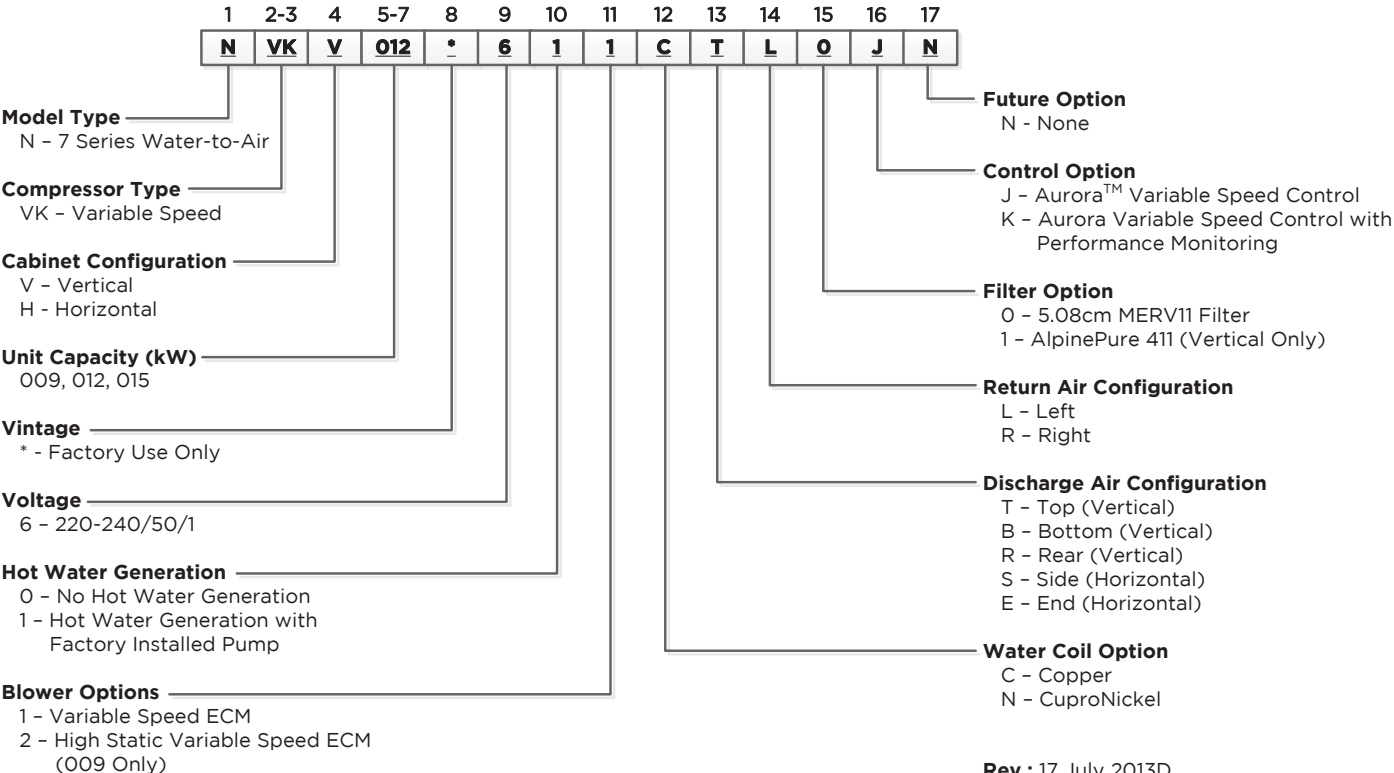

EN 14511 Performance Ratings

7 Series - 50 Hz - EN 14511 Data

Variable Speed ECM & X13 ECM Motors

					Cooling Tower		Water-to Brine		Control Cabinet		Close Control		Water		Brine		Water Loop	
Model	Capacity Modulation	Flow Rate			Cooling EWT 30°C		Cooling EWT 10°C		Cooling EWT 15°C		Cooling EWT 30°C		Heating EWT 10°C		Heating EWT 0°C		Heating EWT 20°C	
		Water, l/s	Air, l/s		Capacity Output, kW	EER (W/W)	Capacity Output, kW	EER (W/W)	Capacity Output, kW	EER (W/W)	Capacity Output, kW	EER (W/W)	Capacity Output, kW	COP	Capacity Output, kW	COP	Capacity Output, kW	COP
			clg	htg														
009	Full	0.76	614	708	9.34	4.7	11.03	9.1	13.43	10.5	10.03	5.1	12.79	4.2	10.19	3.5	15.53	5.0
	Part	0.44			3.33	5.4	3.86	10.0	4.46	11.9	3.65	6.2	4.26	5.7	3.23	4.2	5.41	7.4
012	Full	0.88	708	850	10.74	4.4	14.45	9.5	16.17	9.4	11.32	4.4	16.30	4.0	13.08	3.3	19.98	4.6
	Part	0.47			4.57	6.2	5.49	10.6	5.29	13.5	4.64	5.7	5.63	5.9	4.26	4.2	7.23	7.8
015	Full	1.01	850	1038	14.75	4.2	17.81	8.5	20.03	8.4	13.84	4.0	19.49	4.0	15.45	3.3	23.84	4.6
	Part	0.60			5.54	5.2	6.77	9.4	6.52	11.0	5.31	4.5	6.42	4.9	5.03	4.0	8.03	5.9

9/5/2014

Cooling capacities based upon 27°C DB, 19°C WB entering air temperature for cooling tower and water to brine, 35°C DB and 24°C WB for control cabinet, and 24°C DB and 17°C WB for close control.

Heating capacities based upon 20°C DB, 15°C WB entering air temperature

7 Series Design Features



- ① **VARIABLE SPEED COMPRESSOR:** High efficiency permanent magnet scroll compressor mated with high efficiency electronic drive providing 20-100% variable capacity, soft starting, ultra high efficiency, and lowest operating noise
- ② **DOUBLE ISOLATED COMPRESSOR:** Compressor is double isolation mounted to reduce noise and vibration
- ③ **AURORA ADVANCED VARIABLE SPEED CONTROLS & AID TOOL:** Aurora Controls with the AID Tool provide advanced service diagnostics; this device provides setup and configurations as well as real-time sensors for fault and lockout history, plus energy and refrigeration monitoring as standard features, that can all be monitored on the handheld AID Tool and much more
- ④ **OPTIONAL HOT WATER ASSIST:** Provides free hot water in cooling and very high efficiency hot water generation in heating mode
- ⑤ **COAXIAL HEAT EXCHANGER:** Standard large high efficiency copper (optional cupronickel) coax with our exclusive void-free and robotically applied ThermaShield insulation coating
- ⑥ **ELECTRONIC EXPANSION VALVE:** High efficiency bi-direction electronic expansion valve provides the ultimate in accurate control for the highest efficiency at any condition
- ⑦ **AIR COIL:** Large air coil is designed for maximum efficiency and moisture removal; exclusive FormiShield Plus double coated for superior protection from formicary corrosion and patented 11 element fin design with rifled tubing
- ⑧ **DISCHARGE MUFFLER:** Helps quiet compressor gas pulsations
- ⑨ **ECM BLOWER MOTOR:** High efficiency and ultra-flexible ECM blower motors provide ultra-quiet operation
- ⑩ **FILTER RACK:** Filter rack holds 2.54cm or 5.08cm filters (field changeable) with exclusive snap on filter door
- ⑪ **FILTER:** High holding capacity 5.08cm Pleated MERV 11 filter is standard and 101.6mm pleated MERV 11 Is optional
- ⑫ **SWIVEL LOOP CONNECTIONS:** Leak free swivel water connections provide a hand tight gasket connection that easily handles the temperature extremes of geothermal earth loops
- ⑬ **INSULATION:** Cleanable foil lined insulation to prevent mold growth; corrosion resistant composite drain pan
- ⑭ **CABINET FINISH:** Heavy gauge galvanized sheet metal cabinet has 1,000 hr. salt spray rated gray powder coat paint for long life
- ⑮ **ACCESS PANELS:** All access panels are lift out type for easier removal and servicing
- ⑯ **HINGED CONTROL BOX:** Hinged removable control box
- ⑰ **HOT WATER GENERATOR SWITCH & AID TOOL PORT:** Hot water generator switch for easy enabling/disabling of the hot water generator pump; AID Tool port provides quick AID Tool connection
- ⑱ **CORROSION RESISTANT COMPOSITE DRAIN PAN**

7 Series Design Features cont.

Introducing the 7 Series

- Latest technology compressors
 - High efficiency permanent magnet scroll compressor mated with high efficiency electronic variable speed drive providing 20-100% variable capacity, soft starting, ultra high efficiency and ultra low operating noise.
- ECM blower motor options
 - ECM blower motors for the highest in efficiency and airflow flexibility
- **Efficiency** - Variable speed compressor provides some of the highest efficiencies available for improved seasonal EER/COP which reduces energy use.
- **More Even Temperatures** - Nearly continuous operation results in more even temps in the home.
- **Soft Start Variable Speed Compressor** - VS Drive Soft Start provides quieter starting and operation with no 'light flicker' commonly associated with air conditioning or heat pumps. No IntelliStart is required.
- **Quieter Operation** - Typical operation is at lower compressor speed, and resulting lower airflow means quieter operation.
- **Higher Heating Capacity** - The variable speed unit provides 20% higher heating capacity than comparable dual capacity or single speed compressor unit for reduced loop length and equipment size for a given cooling capacity.
- **'Active' Dehumidification** - In active dehumidification mode, the VS unit monitors the air coil conditions and adjusts compressor speed and airflow operation to maximize the moisture removal based upon a dehumidistat call from the thermostat for improved dehumidification.
- **'SuperBoost' Mode** - Occasionally there can be a requirement for a short term 'boost' of cooling capacity during a large party etc. The user can then select 'SuperBoost' mode on the thermostat which will allow the variable speed system to ramp up an extra 30% of cooling capacity if needed.
- **Communicating Digital Thermostats** - The Aurora controls system features either mono-chromatic or color touch screen graphic display thermostats for user interface with the variable speed system. These displays not only feature easy to use graphical interface but display alerts and faults in plain English.
- **Aurora Communicating Control Features**
 - Traditional Safety Sensors - HP, LP, condensate overflow, freeze detection loop, freeze detection air coil.
 - Variable Speed and EEV Watchdog Circuit - Drive control continually monitors the VS compressor for proper operation and digitally notifies the Aurora Control of any faults.
 - Communicating Modular Design - Communicating modular design for flexibility and expandability.
 - Intelligent hot water assist control - The Aurora control determines operation of hot water assist dependent upon system parameters to maximize overall system efficiency. Selectable hot water set points through the AID Tool.
 - Electronic Expansion Valve for improved refrigerant control and high efficiency.
- **Loop Pump Slaving** - for multiple units on one flow center with either variable speed, single, or dual capacity units. It even works with our legacy controls.
- **Electric Heat Powered Blower And Controls** - Provides emergency heat in the event of an open compressor circuit breaker.
- **Advanced Service Features**
 - Aurora Controls with the AID Tool provide advanced service diagnostics. With this device setup and configurations as well as real-time sensors, fault and lockout history can be monitored and much more. This device is required for setup and troubleshooting of the 7 Series Unit.
 - The 7 Series features refrigeration service sensors as a standard feature. Now superheat, subcooling, refrigerant pressures and various temperatures needed to diagnose unit problems are readily available at your finger tips in the AID Tool right out of the box.
 - Energy Monitoring - With this standard sensor kit installation, the Aurora Control will feature power monitoring of the compressor, blower, and electric heat. The information can be displayed on AID Tool, selected thermostats or thru AWL.
 - Performance Monitoring (optional) - With this optional field or factory installed sensor kit, the Aurora controls can measure actual capacity and performance of the heat pump. The information can be displayed on AID Tool or thru AWL.
 - Advanced communication to the VS drive with faults, electrical, and operational information for quick diagnosis.
 - Aurora can be internet capable simply by adding the Aurora WebLink (AWL). This device will connect your Aurora system to web for remote monitoring and control. It also comes standard with an SD disc drive for storing operating and performance data. Providing 'black box' capability. (Future Availability)
- **Communicating Digital Thermostats** - The Aurora controls system features either mono-chromatic or color touch screen graphic display thermostats for user interface with the 7 Series system. These displays not only feature easy to use graphical interface but display alerts and faults in plain English.

7 Series Design Features cont.

- **Cabinet Design** – Improved design of access panels, control box and filter rack.
- **Cabinet Configurations** – Top or rear air discharge for upflow or bottom discharge for counterflow installations in vertical units, side or end discharge for horizontal units.
- **Cupronickel Heat Exchanger**
- **High Static Blower Option** (009kW ton only)

Application Flexibility

- Safe, efficient operation in a wide range of liquid temperatures (-6.7°C to 48.9°C) and flow rates (as low as 1.5 gpm/ton in open loop applications when EWT >10°C)
- Top or rear air discharge for upflow or bottom discharge for counterflow installations in vertical units, side or end discharge for horizontal units
- True left or right return air locations—vertical and horizontal units include filter rack/duct collar
- Variable-speed ECM blowers permit various duct applications with flexible airflow selection
- Narrow cabinet for easy movement through doorways
- Internally trapped condensate piping on vertical units for neat, compact installation
- Optional field-installed auxiliary electric heater
- Corner-located electrical box for field wiring from two sides
- Circuit breaker protected loop pump power block for easy wiring
- 2 relays to control field-mounted accessories
- Field-selectable freeze detection setting for well or closed loop systems
- Loop pump slaving feature allows multiple units to share one flow center (standard on variable speed systems)

Operating Efficiencies

- EN14511 rating for heating COPs, cooling EERs, and low water flow requirements
- Optional hot water generator with internal pump generates hot water at considerable savings while improving overall system efficiency
- High-stability electronic expansion valve delivers optimum refrigerant flow over a wide range of conditions and provides bidirectional operation without troublesome check valves
- Efficient variable speed scroll compressors operate quietly
- Oversized coaxial tube water-to-refrigerant heat exchanger operates at low liquid pressure drops
- Convolute copper water tube functions efficiently at low flow rates
- Oversized rifled copper tube/lanced aluminum fin air-to-refrigerant heat exchanger provides high efficiencies at low-face velocity with patented 11 element fin design
- Large, low-RPM blowers with ECM motors provide quiet and efficient air movement with high static capability
- Utilizes the ozone-friendly R-410A refrigerant which produces higher efficiencies and warmer discharge air temperatures

Service Advantages

- Hinged/removable control box for added serviceability
- Removable panels: three for the compressor compartment and one (on horizontals) or two (on verticals) for the air handling compartment to provide quick access to all internal components with ductwork in place
- Easily accessible electronic expansion valve
- Brass, swivel-type water connections for quick connection union, and elimination of wrenches and sealants during installation; sweat type connections are on the hot water generator
- Insulated divider and separate air handling/compressor access panels permit service testing without air bypass
- Designed for front access in tight applications
- LED fault and status lights on the Aurora board with memory for easy diagnostics
- Aurora AID Tool provides enhanced service information via communication directly with the Aurora control including sensor inputs, fault history, and much more
- Detachable thermostat connection strip for wiring convenience
- Hot water generator pump shut-off switch for easy startup and service
- Control box and blower motors have quick-attach wiring plugs for easy removal
- Internal drop-out blower with permanently-lubricated ball bearing motor
- Blower and transformer powered from auxiliary heat supply (when installed) to provide emergency heat with open compressor circuit breaker
- High and low pressure service ports in refrigerant circuit
- High and low pressure sensors as well as discharge, suction, heating/cooling liquid lines, EWT, LWT and LAT temperature sensors for ease of service via the AID Tool
- View subcooling and superheat on the AID Tool
- Energy monitoring is standard on the 7 Series variable speed system; Easily check power consumption of the compressor, blower and auxiliary heat via the AID Tool or thermostat
- View heat of extraction/rejection on the AID Tool when the Performance option is installed

Product Quality

- Heavy-gauge steel cabinets are painted with durable powder coat paint for long lasting beauty and service
- Coaxial heat exchanger, refrigerant suction lines, hot water generator coil, and all water pipes are fully insulated to reduce condensation problems in low temperature operation
- FormiShield Plus™ air coils are double coated for extended life
- Noise reduction features include discharge muffler, double isolation mounted compressors and soft starting variable speed compressors and blower motors;

7 Series Design Features cont.

insulated compressor compartment; interior cabinet insulation using 12.7mm coated glass fiber; all units include compressor blanket for quiet operation

- Safety features include high-pressure, low-pressure, and loss of charge refrigerant controls to protect the compressor, condensate overflow protection, freeze detection sensor to safeguard the coaxial heat exchanger and air coil, blower start detection, hot water high-limit hot water generator pump shutdown, compressor monitoring, and fault lockout enables emergency heat and prevents compressor operation until thermostat or circuit breaker is reset

Microprocessor Benefits

- Communicating monochromatic or color digital auto-changeover thermostat with 3-stage heating/2-stage cooling holds precise temperature and provides varying blower speed control
- Component sequencing delays for quiet startup, shutdown, and timed staging of auxiliary electric heat
- ECM blower speed control provides higher supply air temperature in heating, better dehumidification in cooling, and quiet operation at reduced airflows in all modes
- Hot water limit prevents scalding, and pump shuts down automatically when full unit capacity is needed for heating
- Communication capability for future expansions

Options and Accessories

- **Communicating Digital Thermostats**
 - *Monochromatic Graphic Display Thermostats:* For user interface with the Aurora system; these displays not only feature easy to use graphical interface but display alerts and faults in plain English. When Energy Monitoring is added, instantaneous usage is displayed on the thermostat itself.
 - *Color Touch Screen Graphic Display Thermostats:* For user interface with the Aurora system; these displays not only feature easy to use graphical interface but display alerts and faults in plain English. When Energy Monitoring is added not only instantaneous usage is displayed but also weekly and annual consumptions are stored and graphed. Other features include full color implementation, user loaded background photos, and USB port for easy configuration and software updates.
- **Performance Monitoring Kit** - With this optional sensor kit installation, the Aurora controls can measure actual capacity and efficiency performance of the heat pump; the information can be displayed on the AID Tool or through AWL.
- **IntelliZone2 Zone System** - The IntelliZone2 zoning system provides up to 6 zones (Variable Speed), 4 zones (Dual Capacity), or 2 zones (Single Speed) of individualized comfort via communication to the Aurora Control System.

- **AID Tool** - The Aurora Interface and Diagnostics (AID) Tool is a plug-in configuration and troubleshooting tool for the Aurora Control System.
- **Aurora WebLink (AWL) (Future Availability)** - The Aurora Control System can be made internet capable simply by adding the Aurora WebLink (AWL) device. The AWL will connect your Aurora system to the web for remote monitoring and control. It also comes standard with an SD disc for storing operating and performance data providing true 'black box' capability for troubleshooting.
- **Optional Cupronickel Heat Exchangers** - for open loop applications.
- **Optional Hot Water Generator** - with internally mounted pump and water heater plumbing connector.
- **Optional High Static ECM Blower Motor** - for high static applications (009kW only).
- **24 Volt 25.4mm Electronic Air Cleaner**
- **90% Efficient, Cleanable Electrostatic Filters**
- **Closed Loop Variable Speed Flow Center**
- **Closed Loop Variable Speed Non-Pressurized Flow Center**
- **Open Loop Modulating Water Valve**
- **Auxiliary Electric Heater**
- **Hose Kits**
- **Additional Accessory Relay**
- **Alpinepure 50.8mm Merv 13 Filter**
- **Alpinepure 101.6mm Merv 11 Filter**

Manufacturing Quality

- All units are computer run-tested, with conditioned source water, in all modes to ensure efficiency and reliability
- All refrigerant brazing is performed in a nitrogen atmosphere
- All units are deep evacuated to less than 150 microns prior to refrigerant charging
- All joints are helium leak-tested to ensure an annual leak rate of less than 7.1 grams
- All major components bar coded; eliminating possibility of mismatched parts built into unit
- All assembly technicians thoroughly trained in proper quality procedures
- All units have model number and serial number embedded in control for local or remote retrieval
- WaterFurnace International, Inc. is an ISO 9001:2008 certified manufacturing facility
- WaterFurnace International, Inc. engineering labs are ISO 17025 accredited

The Aurora™ Advanced VS Control System

Aurora Advanced VS Control

Aurora Advanced VS Control System is a complete residential and commercial comfort system that brings all aspects of the HVAC system into one cohesive module network. The Aurora Advanced VS Control features the Aurora Base Control (ABC) and the Aurora Expansion Board (AXB). The variable speed drive communicates to the Aurora Control and provides variable capacity and envelope control. The ABC features microprocessor control and HP, LP, loss of charge, condensate and freeze detection, over/under voltage faults, along with communicating thermostat capability for complete fault detection text at the thermostat. Aurora uses the Modbus communication

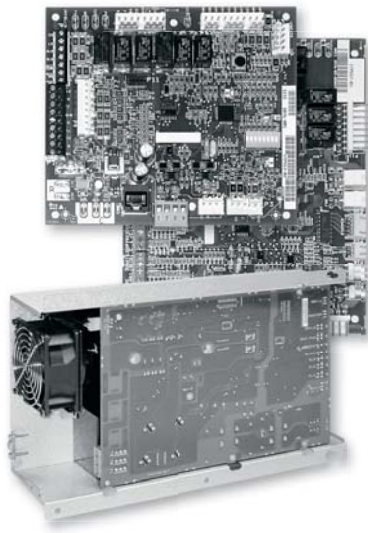

protocol to communicate between modules. Each module contains the logic to control all features that are connected to the module. The ABC has two Modbus channels. The first channel is configured for connecting to devices such as a communicating thermostat, expansion board, or other devices. The second channel is configured for connecting the Aurora Interface Diagnostics Tool (AID Tool).



The Aurora AXB expands on the capability of the ABC control board. The additional features include active dehumidification, SuperBoost cooling mode, loop pump linking, intelligent hot water generator control, variable speed pump capability, and also allows for optional energy, refrigeration, and performance monitoring add-on sensor kits. The AXB also features a second field configurable accessory relay, and two home automation inputs that are AID configurable for different types of alarms from sump pumps to home security. The Smart Grid input is AID configurable with many options to react to Utility controlled relay operation for On Peak optimization. The AXB also expands the communication capability for IntelliZone2 ready operation as well as other expansion with the ClimateTalk protocol.

Aurora Control Features	Description	Aurora Advanced VS
Advanced Microprocessor Features	Smart Grid, Home Automation Alarm Inputs, and Accessory2 Relay (HRV/ERV)	•
Advanced Hot Water Generator Control	Microprocessor and separate power relay for Hot Water Generator Pump with digital temperature monitoring and multiple HWG setpoint selection.	•
Advanced Speed Pump Control	Microprocessor and separate power relay for loop pump and inline circuit breakers and loop pump slaving.	•
Variable Speed Pump	Capable of setup, monitoring and controlling a variable speed flow center.	•
Active Dehumidification	Coil temperature is monitored and air flow is reduced for maximum latent moisture removal.	7 Series Variable Speed Only
SuperBoost	Allow the variable speed compressor to ramp up an extra 30% of cooling capacity if needed. This extra 'SuperBoost' will only be available for a 24 hr period and then the unit will revert to normal operation.	•
Smart Grid/Utility Input	Allows simple input to externally enable of occupied/unoccupied mode for basic utility time of use programs.	Dry Contact x1
Home Automation Alarm Input	Allows simple input to signal sump, security, or smoke/CO sensor alarms from other home automation or security systems. The two inputs can be field configured to a number of options and logic.	Dry Contact x2
HAN/Smart Grid Com (AWL and Portal) Kit	Allows direct communication of the Aurora to Smart Meters, Home Automation Network and Internet.	Optional AWL
IntelliZone2® Compatibility	IntelliZone2 communicates to the heat pump via the AXB board. IntelliZone requires traditional thermostat inputs and is not compatible with the 7 Series.	Optional IntelliZone2

Service Device	Description	Aurora Advanced VS
 Aurora Interface and Diagnostics (AID) Tool	<p>Allows setup, monitoring and troubleshooting of any Aurora Control.</p> <p>NOTE: Although the ABC has basic compatibility with all Aurora, new product features may not be available on older AID Tools. To simplify the basic compatibility ensure the version of AID is at least the same or greater than the ABC software version.</p>	<p>For Service (Ver. 2.xx or greater)</p>

The Aurora Advanced VS Control System cont.

Add On Control Feature Kits (field or factory installed)	Description	Aurora Advanced VS
Geo Energy Monitoring Kit	Monitors real time power consumption of compressor, blower, aux heat and pump. Requires thermostat TPCM32U04 or TPCC32U01.	Standard
Refrigeration Monitoring Kit	Monitors real time pressures, temperatures, superheat, and subcooling.	Standard
Performance Monitoring Kit	Monitors air and water temperatures, and water flow rate and calculates heat of extraction/rejection.	Optional Sensor Kit
Data Logging (AWL) Kit	Allows data logging of up to 12 months. Can also be temporarily installed.	Optional
HAN/Smart Grid Com (AWL and Portal) Kit	Allows direct communication of the Aurora to Smart Meters, HAN, and internet.	Optional

Add On Thermostats and Zoning	Description	Aurora Advanced VS
 <p>TPCM32U04 - MonoChrome Communicating Thermostat</p>	Elite Stat with full English fault codes and alerts, communicating thermostat; Required for viewing Energy Monitoring. Monochrome thermostat allows instantaneous energy measurement only.	Optional
 <p>TPCC32U01 - Color Touchscreen Communicating Thermostat</p>	4.3 in. color touchscreen communicating thermostat with full English fault codes and alerts; Required for viewing Energy Monitoring. Color thermostat allows instantaneous and 13 month history.	Optional
 <p>IntelliZone2® Zoning</p>	Includes color main thermostat and up to 6 zones (with variable speed), 4 zones (with dual capacity), and 2 zones (with single speed). There are 3 thermostat options (MasterStat, SensorStat, ZoneStat).	Optional

NOTES: The IntelliZone2 or one of the communicating thermostats shown above must be used to control the variable speed heat pump.

Aurora Advanced VS Control Features

NOTE: Refer to the Aurora Advanced VS Control Application and Troubleshooting Guide and the Instruction Guide: Aurora Interface and Diagnostics (AID) Tool for additional information.

Control Features

Software ABC VS Version 2.0 Variable Capacity Compressors

- Random start at power up
- Anti-short cycle protection
- High and low pressure cutouts
- Loss of charge
- Water coil freeze detection
- Air coil freeze detection
- Over/under voltage protection
- Condensate overflow sensor
- Load shed
- Dehumidification (where applicable)
- Emergency shutdown
- Diagnostic LED
- Test mode push button switch
- Two auxiliary electric heat outputs
- Alarm output

- Accessory output with N.O. and N.C.
- Modbus communication

Variable Speed ECM Blower Motor

A variable speed ECM blower motor is driven directly using the onboard PWM output. Multiple blower speeds are available based upon requirements of the compressor and electric heat. The blower speeds can be changed either by the variable speed ECM manual configurations mode method or by using the Aurora AID Tool directly.

Advanced Hot Water Generator Control (Domestic Hot Water Option)

An AID Tool selectable temperature limit and microprocessor control of the process is featured. This will maximize hot water generation and prevent undesirable energy use. An alert will occur when the hot water input temperature is at or above the set point (54.4°C default) for 30 continuous seconds. This alert will appear as an E15 on the AID Tool and the hot water pump de-energizes. Hot water pump operations resume on the next compressor cycle or after 15 minutes of continuous compressor operation during the current thermostat demand cycle. Since compressor hot gas temperature is dependent on

The Aurora Advanced VS Control System cont.

loop temperature in cooling mode, loop temperatures may be too low to allow proper heating of water. The control will monitor water and refrigerant temperatures to determine if conditions are satisfactory for heating water.

VS Drive and Envelope Control

The VS drive operates the compressor between 20 and 100% capacity. The VS drive communicates any out of refrigerant envelope conditions to the Aurora and will attempt to adjust the compressor speed to keep within the envelope. These conditions are measured using the discharge and suction pressure transducers, discharge temperature, and current sensors of the drive.

IntelliZone2 Zoning Compatibility (Optional IntelliZone2 Zoning)

A dedicated input to connect and communicate with the IntelliZone2 (IZ2) zoning system is provided on P7 on the AXB control board. There is a dedicated communication port using a proprietary ModBus protocol. The AXB is standard on variable speed systems. An AXB can be added to other selected ABC only systems as well. Then an advanced communicating IntelliZone2 zoning system can be added to ABC-only systems. Consult the IntelliZone2 literature for more information.

Electronic Expansion Valve (EEV)

The electronic expansion valve is operated by the EEV board and is set to maintain optimal superheat setting for maximum efficiency. All operation parameters are communicated to the VS drive and the Aurora system.

Variable Speed Pump

This input and output are provided to drive and monitor a variable speed pump. The VS pump output is a PWM signal to drive the variable speed pump. The minimum and maximum level are set using the AID Tool. 50% and 100% are the default settings respectively. The VS data input allows a separate PWM signal to return from the pump giving fault and performance information. Fault received from the variable speed pump will be displayed as E16.

Modulating Water Valve

This output is provided to drive a modulating water valve. Through advanced design the 0-10VDC valve can be driven directly from the VS Pump output. The minimum and maximum level are set in the same way as the VS pump using the AID Tool. 50% and 100% are the default settings respectively.

Loop Pump Linking

This input and output are provided so that two units can be linked together with a common flow center. When either unit has a call for loop outputs, both unit's loop pump relays and variable speed pumps are energized. The flow center then can simply be wired to either unit. The output from one unit should be routed to the input of the other. If daisy chained, up to 16 heat pumps can be wired and linked together in this fashion.

Advanced Communication Ports

Communication ports P6 and P8 will provide future expansion via dedicated protocols. These are for future use.

Smart Grid/On Peak (SG) Input

The 'Smart Grid/On Peak' input was designed to allow utilities to utilize simple radio controlled switches to control the On Electric Peak behavior of the 5 and 7 Series Geothermal Heat Pumps and provide demand reduction. With a closed contact signal, this input will limit the operation and thus the power consumption of the unit by disabling the compressor and electric heat as long as the signal is present. Code 7 will flash on the Green LED signifying the 'On Peak' mode. On Peak will also display on communicating thermostats.

Home Automation 1 and 2 Inputs

The Home Automation inputs are simple closed contact inputs that will trigger an AID Tool and thermostat alert for the homeowner. These would require optional sensors and/or equipment for connection to the AXB board. With two inputs, two different sensors can be selected. The selected text will then be displayed on the AID Tool and communicating thermostats. These events will NOT alter functionality or operation of the heat pump/accessories and is for homeowner/service notification only.

Home Automation 1 - E23 HA1

With a closed dry contact signal, this input will cause an alarm and Alert Code 23 to indicate on the stat or flash on ABC. The AID Tool will allow configuration of this input between the following selections:

- *No Action*
- *Home Automation Fault* [no lockout info only] - Output from home automation system
- *Security Alarm* [no lockout info only] - Output from home security
- *Sump Alarm Fault* [no lockout info only] - Switch output from sump sensor
- *Smoke/CO Alarm Fault* [no lockout info only] - Switch output from Smoke/CO sensor
- *Dirty Filter Alarm* [no lockout info only] - Output from dirty filter sensor

The Aurora Advanced VS Control System cont.

Home Automation 2 - E24 HA2

With a closed dry contact signal, this input will cause an alarm and Alert Code 24 to indicate on the stat or flash on ABC. The AID Tool will allow configuration of this input between the following selections:

- *No Action*
- *Home Automation Fault* [no lockout info only] - Output from home automation system
- *Security Alarm* [no lockout info only] - Output from home security
- *Sump Alarm Fault* [no lockout info only] - Switch output from sump sensor
- *Smoke/CO Alarm Fault* [no lockout info only] - Switch output from Smoke/CO sensor
- *Dirty Filter Alarm* [no lockout info only] - Output from dirty filter sensor

Monitoring Sensor Kits

Energy Monitoring

(Standard on all 7 Series units)

The Energy Monitoring Kit includes two current transducers (blower and electric heat) added to the existing two compressor sensors so that the complete power usage of the heat pump can be measured. The AID Tool provides configuration detail for the type of blower motor and a line voltage calibration procedure to improve the accuracy. This information can be displayed on the AID Tool or selected communicating thermostats. The TPCM32U04 will display instantaneous energy use while the color touchscreen TPCC32U01 will, in addition, display a 13 month history in graph form.

Refrigerant Monitoring

(Standard on all 7 Series units)

The optional Refrigerant Monitoring Kit includes two pressure transducers, and three temperature sensors, heating liquid line, suction temperature and existing cooling liquid line (FP1). These sensors allow the measurement of discharge and suction pressures, suction and liquid line temperatures as well as superheat and subcooling. This information will only be displayed on the AID Tool.

Performance Monitoring

(Optional sensor kit)

The optional Performance Monitoring Kit includes three temperature sensors, entering and leaving water, leaving air temperature and a water flow rate sensor. With this kit heat of extraction and rejection will be calculated. This requires configuration using the AID Tool for selection of water or antifreeze.

Special Modes and Applications

Communicating Digital Thermostats

The Aurora VS controls system also requires either the monochromatic or color touch screen graphic display thermostats for user interface. These displays not only feature easy to use graphical interface but display alerts and faults in plain English.

'SuperBoost' Cooling Mode

Occasionally there can be a requirement for a short term 'boost' of cooling capacity during a large party etc. The 7 Series allows the user to select 'SuperBoost' mode on the thermostat which will allow the 7 Series VS to ramp up an extra 30% of cooling capacity if needed. This extra 'SuperBoost' will only be available for a 24 hr period and then the unit will revert to normal operation. The short term boost does not affect ground loop sizing since it is limited in operation. Continuous use of SuperBoost will result in overheating of the ground loop.

Dehumidification - Active

Active dehumidification will only activate during cooling operation and is based upon the humidity setpoint of the thermostat being at least 5% below the actual relative humidity and being within the temperature parameters described here. The green status LED will flash code 2 when active. The unit can operate a maximum of 1.1°C below the cooling setpoint. The compressor will ramp up and airflow will begin at a low level. Airflow is then reduced periodically until air coil temperature setpoint is reached. If coil temperature continues to drop, the airflow is increased until air coil setpoint is maintained. After 20 minutes of operation in the Active Dehumidification mode, normal cooling operation will resume for 5 minutes. This cycle continues until the dehumidification setpoint is reached, room temperature is more than 1.1°C below cooling setpoint, or more than 0.6°C above cooling setpoint (normal cooling takes over). In IntelliZone2 systems, the main zone will remain open during active dehumidification.

Field Hardware Selectable Options

ABC Field Selectable Options via Button (SW1)

Test/Configuration Button (See SW1 Operation Table)

Test Mode

The control is placed in the test mode by holding the push button switch on the ABC SW1 for 2 - 5 seconds. In test mode most of the control timings will be shortened by a factor of sixteen (16). LED3 (green) will flash at 1 second on and 1 second off. Additionally, when entering test mode LED1 (red) will flash the last lockout one time. Test mode will automatically time out after 30 minutes. Test mode can be exited by pressing and holding the SW1 button for 2 to 5 seconds or by cycling the power. **NOTE:** Test mode will automatically be exited after 30 minutes.

The Aurora Advanced VS Control System cont.

Variable Speed ECM Configuration Mode

The control is placed in the variable speed ECM configuration mode by holding the push-button switch SW1 for 5 to 10 seconds, the high, low, and G variable speed ECM speeds can be selected by following the LED display lights. LED2 (yellow) will fast flash when entering the variable speed ECM configuration. When setting G speed LED3 (green) will be continuously lit, for low speed LED1 (red) will be continuously lit, and for high speed both LED3 (green) and LED1 (red) will be continuously lit. During the variable speed ECM configuration mode LED2 (yellow) will flash each of the 12 possible blower speeds 3 times. When the desired speed is flashed press SW1, LED2 will fast flash until SW1 is released. G speed has now been selected. Next select low speed, and high speed blower selections following the same process above. After third selection has been made, the control will exit the variable speed ECM configuration mode. Aux blower speed will remain at default or current setting and requires the AID Tool for adjustment.

Reset Configuration Mode

The control is placed in reset configuration mode by holding the push button switch SW1 on the ABC for 50 to 60 seconds. This will reset all configuration settings and the EEPROM back to the factory default settings. LED3 (green) will turn off when entering reset configuration mode. Once LED3 (green) turns off, release SW1 and the control will reset.

ABC DIP Switch (SW2)

- SW2-1** FP1 Selection – Low water coil temperature limit setting for freeze detection. On = -1.1°C; Off = -9.4°C.
- SW2-2** FP2 Selection – Low air coil temperature limit setting for freeze detection. On = -1.1°C; Off = Not Used
- SW2-3** RV – O/B - thermostat type. Heat pump thermostats with “O” output in cooling or “B” output in Heating can be selected. On = O; Off = B.
- SW2-4** Access Relay Operation (P2)
and 2-5

Access Relay Operation	SW2-4	SW2-5
Cycle with Blower	ON	ON
Cycle with Compressor	OFF	OFF
Water Valve Slow Opening	ON	OFF
Cycle with Comm. T-stat Hum Cmd	OFF	ON

- SW2-6** CC Operation – selection of single or dual capacity compressor. On = Single Stage; Off = Dual Capacity
NOTE: SW2-6 is not applicable to the 7 Series
- SW2-7** Lockout and Alarm Outputs (P2) – selection of a continuous or pulsed output for both the LO and ALM Outputs. On = Continuous; Off = Pulsed
NOTE: SW2-7 is not applicable to the 7 Series
- SW2-8** Future Use

Alarm Jumper Clip Selection

From the factory, ALM is connected to 24 VAC via JW2. By cutting JW2, ALM becomes a dry contact connected to ALG.

Variable Speed ECM Blower Speeds

The blower speeds can be changed either by using the variable speed ECM manual configurations mode method or by using the Aurora AID Tool directly (see Instruction Guide: Aurora Interface and Diagnostics (AID) Tool topic).

AXB DIP Switch (SW1)

DIP 1 - ID: This is the AXB ModBus ID and should always read On.

DIP 2 & 3 - Future Use

DIP 4 & 5 - Accessory Relay2: A second, DIP configurable, accessory relay is provided that can be cycled with the compressor 1 or 2, blower, or the Dehumidifier (DH) input. This is to complement the Accessory 1 Relay on the ABC board.

Position	DIP 4	DIP 5	Description
1	ON	ON	Cycles with blower or ECM (or G)
2	OFF	ON	Cycles with CC1 first stage of compressor or compressor spd 1-12
3	ON	OFF	Cycles with CC2 second stage of compressor or compressor spd 7-12
4	OFF	OFF	Cycles with DH input from ABC board

Field Selectable Options via Software (Selectable via the Aurora AID Tool)

Many options are field selectable and configurable in Aurora software via the AID Tool. Consult the installation manual or Aurora documentation for further details.

Basic Aurora Safety Features

The following safety features are provided to protect the compressor, heat exchangers, wiring and other components from damage caused by operation outside of design conditions.

Fuse – a 3 amp automotive type plug-in fuse provides protection against short circuit or overload conditions. Anti-Short Cycle Protection – 4 minute anti-short cycle protection for the compressor.

Random Start – 5 to 80 second random start upon power up.

Fault Retry – in the fault condition, the control will stage off the outputs and then “try again” to satisfy the thermostat VS call. Once the thermostat input calls are satisfied, the control will continue on as if no fault occurred. If 3 consecutive faults occur without satisfying the thermostat VS call, then the control will go to Lockout mode.

The Aurora Advanced VS Control System cont.

Lockout - when locked out, the blower will operate continuously in "G" blower speed setting. The Alarm output (ALM) and Lockout output (L) will be turned on. The fault type identification display LED1 (Red) shall flash the fault code. To reset lockout conditions with SW2-8 On, the demand call must be removed for at least 30 seconds. To reset lockout conditions with SW2-8 Off, the demand call must be removed for at least 30 seconds. Lockout may also be reset by turning power off for at least 30 seconds or by enabling the emergency shutdown input for at least 30 seconds.



CAUTION: Frequent cycling of power to the drive can damage the drive! Wait at least 5 minutes between cycles (connecting and disconnecting power to the drive).

Lockout With Emergency Heat - if the control is locked out in the heating mode, and a call for emergency heat is received, the control will operate in the emergency heat mode while the compressor is locked out. The first emergency heat output will be energized 10 seconds after the W input is received, and the blower will shift to high speed. If the control remains locked out, and the W input is present, additional stage of emergency heat will stage on after 2 minutes. When the W input is removed, all of the emergency heat outputs will turn off, and the variable speed ECM blower will shift to low speed.

High Pressure - fault is recognized when the Normally Closed High Pressure Switch, P4-9/10 opens, no matter how momentarily. The High Pressure Switch is electrically in series with the Compressor Contactor and serves as a hardwired limit switch if an overpressure condition should occur.

Low Pressure - fault is recognized when the Normally Closed Low Pressure Switch, P4-7/8 is continuously open for 30 seconds. Closure of the LPS any time during the 30 second recognition time restarts the 30 second continuous open requirement. A continuously open LPS shall not be recognized during the 2 minute startup bypass time.

Loss of Charge - fault is recognized when the Normally Closed Low Pressure Switch, P4-7/8 is open prior to the compressor starting.

Condensate Overflow - fault is recognized when the impedance between this line and 24 VAC common or chassis ground drops below 100K ohms for 30 seconds continuously.

Freeze Detection-Coax - set points shall be either -1.1°C or -9.4°C. When the thermistor temperature drops below the selected set point, the control shall begin counting down the 30 seconds delay. If the thermistor value rises above the selected set point, then the count should reset. The resistance value must remain below the selected set point for the entire length of the appropriate delay to be

recognized as a fault. This fault will be ignored for the initial 2 minutes of the compressor run time.

Freeze Detection-Air Coil - Air Coil Freeze Detection will use the FP2 input to protect against ice formation on the air coil. The FP2 input will operate exactly like FP1 except that the set point is 30 degrees and is not field adjustable.

Over/Under Voltage Shutdown - An over/under voltage condition exists when the control voltage is outside the range of 18 VAC to 30 VAC. If the over/under voltage shutdown lasts for 15 minutes, the lockout and alarm relay will be energized. Over/under voltage shutdown is self-resetting in that if the voltage comes back within range of 18 VAC to 30 VAC for at least 0.5 seconds, then normal operation is restored.

Other Lockouts and Alarms

Several other lockouts and alarms are shown in the Status LED1 (LED1, Red) table with the associated codes visible on the thermostat, ABC Fault LED, and in text in the AID Tool.

Operation Description

Power Up - The unit will not operate until all the inputs and safety controls are checked for normal conditions. The unit has a 5 to 80 second random start delay at power up. Then the compressor has a 4 minute anti-short cycle delay after the random start delay.

Standby - In standby mode the compressor, pump, and blower motor are not active. The RV may be active. The blower and compressor will be off.

Heating Operation - The unit will operate based upon demand as calculated by the room setpoint algorithm. The resulting compressor speed (1-12) will also select an appropriate blower speed for the selected compressor speed. Aux Heat will not be available (on IntelliZone2 Aux Heat is available on compressor speeds 10-12) until after the 12th compressor speed has been operational and still is not satisfying the thermostat, then auxiliary electric heat will be activated.

Emergency Heat (W) - The blower will be started on G speed, 10 seconds later the first stage of electric heat will be turned on. 5 seconds after the first stage of electric heat is energized the blower will shift to Aux speed. If the emergency heat demand is not satisfied after 2 minutes the second electric heat stage will be energized.

Cooling Operation - The unit will operate based upon demand as calculated by the room setpoint algorithm. The resulting compressor speed, speeds 1-9, (speeds 10-12 are reserved for SuperBoost mode only) will also select an appropriate blower speed. The blower mode will also

The Aurora Advanced VS Control System cont.

have the cooling airflow adjustment applied. In all cooling operations, the reversing valve directly tracks the O input. Thus, anytime the O input is present, the reversing valve will be energized.

Blower (G) - The blower will start immediately upon receiving a thermostat G command. If there are no other commands from the thermostat the variable speed ECM will run on low speed until the G command is removed. Regardless of blower input (G) from the thermostat, the blower will remain on low speed for 30 seconds at the end of each heating, cooling, and emergency heat cycle.

Emergency Shutdown - Four (4) seconds after a valid ES input, P2-7 is present, all control outputs will be turned off and remain off until the emergency shutdown input is no longer present. The first time that the compressor is started after the control exits the emergency shutdown mode, there will be an anti-short cycle delay followed by a random start delay. Input must be tied to common to activate.

Continuous Blower Operation - The blower output will be energized any time the control has a G input present, unless the control has an emergency shutdown input present. The blower output will be turned off when G input is removed.

Load Shed - The LS input disables all outputs with the exception of the blower output. When the LS input has been cleared, the anti-short cycle timer and random start timer will be initiated. Input must be tied to common to activate.

Aurora Advanced VS Control LED Displays

These three LEDs display the status, configuration, and fault codes for the control. These can also be read in plain English via the Aurora AID Tool. See the LED tables for further explanation.

Aurora Interface and Diagnostics (AID) Tool

The Aurora Interface and Diagnostics (AID) Tool is a device that is a member of the Aurora network. The AID Tool is used to troubleshoot equipment which uses the Aurora control via Modbus RTU communication. The AID Tool provides diagnostics, fault management, variable speed ECM setup, and system configuration capabilities to the Aurora family of controls. An AID Tool is recommended, although not required, for variable speed ECM airflow settings. The AID Tool simply plugs into the exterior of the cabinet in the AID Tool port.



Status LED (LED3, Green)

Description of Operation	Fault LED, Green
Normal Mode	ON
Control is Non-functional	OFF
Test Mode	Slow Flash
Lockout Active	Fast Flash
Dehumidification Mode	Flash Code 2
Load Shed	Flash Code 5
Emergency Shutdown	Flash Code 6
On Peak Mode	Flash Code 7
Warning! VS Derated	Flash Code 8
Warning! VS SafeMode	Flash Code 9

Configuration LED (LED2, Yellow)

Description of Operation	Configuration LED, Yellow
No Software Overwritten	ECM Setting
DIP Switch Overwritten	Slow Flash
ECM Configuration Mode	Fast Flash
Reset Configuration Mode	OFF

The Aurora Advanced VS Control System cont.

Status LED (LED1, Red)

Red Fault LED	LED Flash Code *	Lockout	Reset/Remove	Fault Condition Summary	ABC Action		AID Tool Display and History	IntelliZone2 and Thermostat Display
					ABC Green Status LED	ABC Red Fault LED		
Normal - No Faults	Off	-	-	-				
Fault-Input	1	No	Auto	Tstat input error. Autoreset upon condition removal.	Normal	Code 1		
Fault-High Pressure	2	Yes	Hard or Soft	HP switch has tripped (>4157 kPa)	Lockout	Code 2	Lockout - E2 High Press	
Fault-Low Pressure	3	Yes	Hard or Soft	Low Pressure Switch has tripped (<276 kPa for 30 continuous sec.)	Lockout	Code 3	Lockout - E3 Low Press	
Fault-Freeze Detection FP2	4	Yes	Hard or Soft	Freeze protection sensor has tripped (<-9.4 or -11 degC for 30 continuous sec.)	Lockout	Code 4	Lockout - E4 Freeze Detection FP2	
Fault-Freeze Detection FP1	5	Yes	Hard or Soft	Freeze protection sensor has tripped (<-9.4 or -11 degC for 30 continuous sec.)	Lockout	Code 5	Lockout - E5 Freeze Detection FPI	
Fault-Condensate Overflow	7	Yes	Hard or Soft	Condensate switch has shown continuity for 30 continuous sec.	Lockout	Code 7	Lockout - E7 Condensate	
Fault-Over/Under Voltage	8	No	Auto	Instantaneous Voltage is out of range. *Controls shut down until resolved.	Lockout	Code 8	Lockout - E8 Over/Under voltage	
Fault-Compressor Monitor	10	Yes	Hard or Soft	Open Crkt. Run, Start or welded cont	Lockout	Code 10	Lockout - E10 Compress Monitor	
Fault-FPI & 2 Snsr Error	11	Yes	Hard or Soft	If FPI or 2 Sensor Error	Lockout	Code 11	Lockout - E11 FPI/FP2 Sensor Error	
Non-Crit-AXBsnsErr	13	No	Auto	Any Other Sensor Error	Normal	Code 13	Alert - E13 Non-Critical AXB Sensor Error	
Crit-AXBsnsErr	14	Yes	Hard or Soft	Sensor Err for EEV or HW	Lockout	Code 14	Lockout - E14 Critical AXB Sensor Error	
Alarm-HotWtr	15	No	Auto	HW over limit or logic lockout. HW pump deactivated.	Normal	Code 15	Alert - E15 Hot Water Temp Limit	
Fault-VarSpdPump	16	No	Auto	Alert is read from PWM feedback.	Normal	Code 16	Alert - E16 Var Spd Pump Err	
Non-CritComErr	18	No	Auto	Any non-critical com error	Normal	Code 18	Alert - E18 Non-Critical Communication Error	
Fault-CritComErr	19	No	Auto	Any critical com error. Auto reset upon condition removal	Normal	Code 19	Alert - E19 Critical Communication Error	
Alarm - Low Loop Pressure	21	No	Auto	Loop pressure is below 21 kPa for more than 3 minutes	Normal	Code 21	No Display	
Alarm - Home Automation 1	23	No	Auto	Closed contact input is present on Dig 2 input - Text is configurable	Normal	Code 23	Alert - E23 Selected choice	
Alarm - Home Automation 2	24	No	Auto	Closed contact input is present on Dig 3 input - Text is configurable	Normal	Code 24	Alert - E24 Selected Choice	
Derate-DriveTemp	41	No	Auto	Drive Temp has reached critical High Temp	Derated	Code 41	Warning! Derated - E41 DriveTemp	
Derate-HIDisTemp	42	No	Auto	Compressor Discharge is exceeded limit for 90 continuous sec.	Derated	Code 42	Warning! Derated - E42 HIDisTemp	
Derate-LoSucPres	43	No	Auto	Suction Pressure is critically low	Derated	Code 43	Warning! Derated - E43 LoSucPres	
Derate-LoConPres	44	No	Auto	Condensing pressure is critically low	Derated	Code 44	Warning! Derated - E44 LoConPress	
Derate-HiConPres	45	No	Auto	Condensing pressure is critically high	Derated	Code 45	Warning! Derated - E45 HiConPress	
Derate-OutPwrLmt	46	No	Auto	Supply Voltage is <208V or Max Pwr is reached due to high pressure	Derated	Code 46	Warning! Derated - E46 OutPwrLmt	
SafeMd-EEVIndCom	47	No	Auto	Com with EEV is interrupted EEV has gone independent mode	SafeMode	Code 47	Warning! SafeMode - E47 EEVIndCom	
SafeMd-EEVOutCom	48	No	Auto	Com with EEV is interrupted EEV has gone independent mode	SafeMode	Code 48	Warning! SafeMode - E48EEVOutCom	
SafeMd-AmbTempSnr	49	No	Auto	Ambient Temperature (Tamb) is <-60 or > 100°C and out of range or invalid	SafeMode	Code 49	Warning! SafeMode - E49	
Fault-DisTempSnr	51	Yes	Hard or Soft	Discharge Sensor (SD) is > 138°C or invalid (-60 to 200°C)	Lockout	Code 51	Lockout! - E51 DisTempSnr	
Fault-SucPrsSnr	52	Yes	Hard or Soft	Suction Pressure (PO) is invalid (0 to 1600 kPa)	Lockout	Code 52	Lockout! - E52 SucPrsSnr	
Fault-ConPrsSnr	53	10x then Yes	Hard or Soft	Low condensing pressure (PD) or invalid (0 to 5998.4 kPa) Retry 10x.	Norm then Lockout	Code 53	Lockout! - E53 ConPrsSnr	
Fault-LowSup Volt	54	Yes	Hard or Soft	Supply Voltage is <175 V (190V to reset) or powered off/on too quickly (<30 sec.)	Lockout	Code 54	Lockout! - E54 LowSupVolt	
Fault-OutEnvelop	55	10x then Yes	Hard or Soft	Comp Operating out of envelope (PO) more than 90 sec. Retry 10x.	Norm then Lockout	Code 55	Lockout! - E55 OutEnvelop	
Fault-OverCurrnt	56	Yes	Hard or Soft	Over current tripped by phase loss, earth fault, short circuit, low water flow, low air flow, or major drive fault.	Lockout	Code 56	Lockout! - E56 OverCurrnt	
Fault-Over/Under Volt	57	Yes	Hard or Soft	DC Link Voltage to compressor is >253V or at minimum Volt.	Lockout	Code 57	Lockout! - E57 Over/Under Volt	
Fault-HIDrivTemp	58	Yes	Hard or Soft	Drive Temp has reached critical High Temp >115°C	Lockout	Code 58	Lockout! - E58HIDrivTemp	
Fault-DrvIntErr: MOC/AOC	59	Yes	Hard or Soft	The MOC has encountered an internal fault or an internal error. Probably fatal.	Lockout	Code 59	Lockout! - E59 DrvIntErr	
Fault-MultSafeMd	61	Yes	Hard or Soft	More than one SafeMode condition is present requiring lockout.	Lockout	Code 61	Lockout! - E61 MultSafeMd	
Fault-LossOfCharge	71	Yes	Hard or Soft	High superheat and high EEV opening % for a long time will trigger a loss of charge fault	Lockout	Code 71	Lockout! - E71 LossCharge	
SafeMd-SucTempSnr	72	No	Auto	Suction Temperature Sensor is invalid (-60 to 200°C)	SafeMode	Code 72	Warning! SafeMode - E72 SucTempSnr	
SafeMd-LATSensor	73	No	Auto	Leaving Air Temperature Sensor is invalid (-60 to 200°C)	Normal	Code 73	Alert - E73 LAT Sensor	
SafeMd-MaxOpPres	74	No	Auto	Suction pressure has exceeded that maximum operating level for 90 sec.	SafeMode	Code 74	Warning! SafeMode - E74 MaxOpPress	

NOTES: *All codes >11 use long flash for tens digit and short flash for the ones digit. 20, 30, 40, 50 etc. are skipped.
Alert! is a noncritical sensor or function that has failed. Normal operation of the heat pump is maintained but service is desired at some point.

The Aurora Advanced VS Control System cont.

ABC Control Board Layout

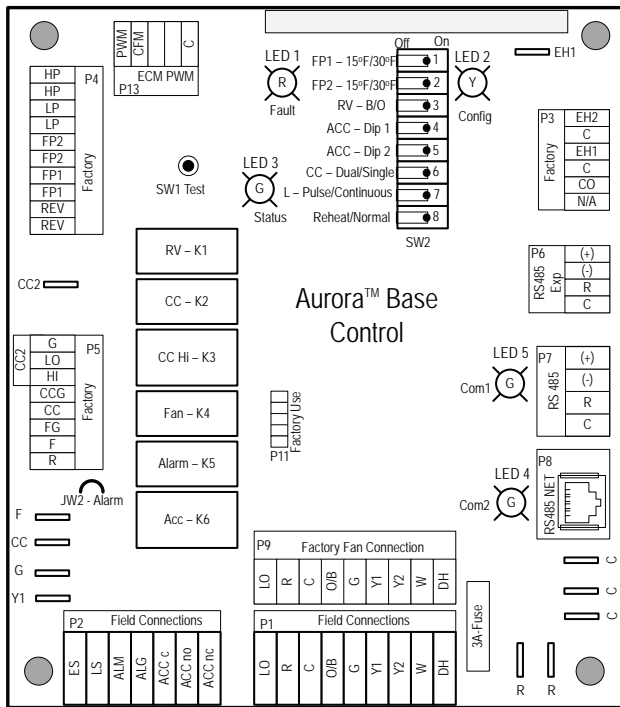

AXB Control Board Layout

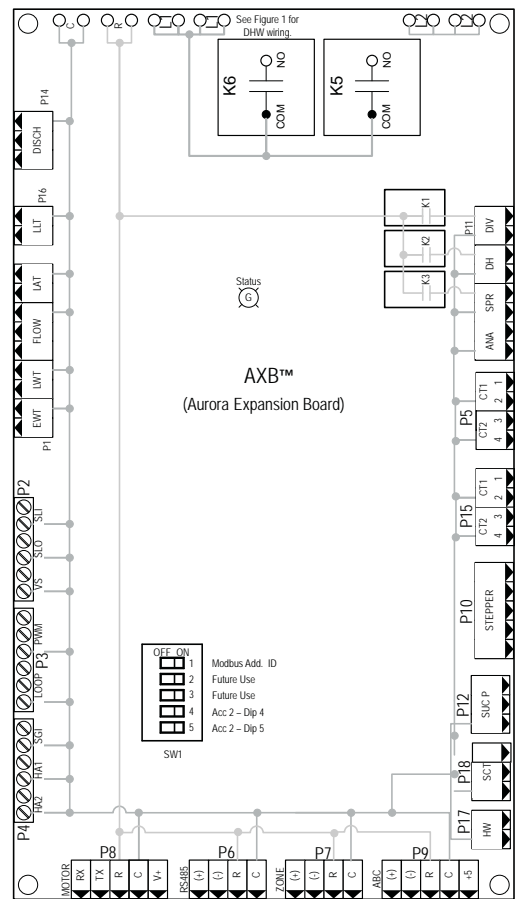

EEV Board Layout

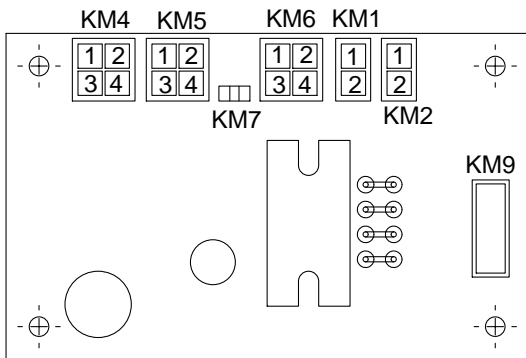

Variable Speed Drive

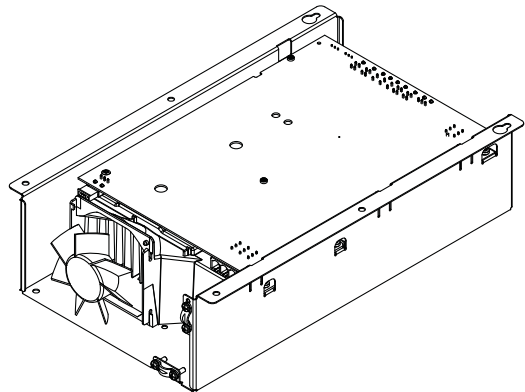

Operation Logic

Heating Mode

When the variable speed controls determine that heating is needed in the space the blower will be turned on, the compressor will be ramped to speed 6 and the loop pump will be started. The compressor will continue to run at speed 6 for 60 seconds for oil circulation. During the 60 second oil circulation the controls will calculate what speed the compressor will need to operate at to maintain the set point in the space. If the compressor is operating at speed 12 and the unit is unable to maintain set point the controls will stage on the electric heat. Electric heat will not operate unless the compressor is already running at speed 12. Every 30 minutes if the compressor has been operating lower than speed 6, the controls will increase the compressor to speed 6 for one minute for oil circulation.

Cooling Mode

When the variable speed controls determine that cooling is needed in the space the blower will be turned on, the reversing valve will be enabled, the compressor will be ramped to speed 6, and the loop pump will be started. The compressor will continue to run at speed 6 for 60 seconds for oil circulation. During the 60 second oil circulation the controls will calculate what speed the compressor will need to operate at to maintain the set point in the space. The compressor will be limited to a maximum of speed 9 for cooling. If additional capacity is needed SuperBoost mode can be enabled from the thermostat allowing the compressor to run at speeds higher than 9 for a period of 24 hours. Every 30 minutes if the compressor has been operating lower than speed 6, the controls will increase the compressor to speed 6 for one minute for oil circulation.

ECM Blower Motor

The variable speed controls will vary the ECM blower output to maintain optimum air flow at each of the 12 compressor speeds. If dehumidification mode is selected during the cooling operation the airflow will be varied to allow for maximum moisture removal.

Variable Speed Loop Pump

The variable speed controls will operate the variable speed loop pump similar to the way the ECM blower motor operates. The speed of the pump will be increased as the compressor speed is increased to maintain adequate water flow.

Safe Mode

The system has encountered an unsafe operating condition that prevents automatic speed control, e.g. lost a sensor signal. To avoid damage to the system, the drive is running the compressor at a fixed speed of 2400 rpm awaiting the problem to be solved and eventually returning to normal operation. If the problem cannot be solved the drive stops and issues an alarm. (See fault/alarm table.)

Derating

The VS compressor utilizes 'envelope control' to maintain performance within operational limits and improve reliability. To accomplish this, pressure sensors for discharge and suction pressure as well as hot gas temperature sensing are used to monitor the conditions in which the compressor operates. The envelope does vary based upon operating speed (rpm). When operating out of these limits the control will attempt to improve the situation by moderating the compressor speed for a larger envelope. When this occurs it can be observed on the Aurora control as an 'E' code. The control will automatically try to resolve the situation. If the situation progresses, a fault and lockout will be generated by the control.

Water Quality

In ground water situations where scaling could be heavy or where biological growth such as iron bacteria will be present, a closed loop system is recommended. The heat exchanger coils in ground water systems may, over a period of time, lose heat exchange capabilities due to a buildup of mineral deposits inside. These can be cleaned, but only by a qualified service mechanic, as special solutions and pumping equipment are required. Hot water generator coils can likewise become scaled and possibly plugged. In areas

with extremely hard water, the owner should be informed that the heat exchanger may require occasional flushing.

Units with cupronickel heat exchangers are recommended for open loop applications due to the increased resistance to build-up and corrosion, along with reduced wear caused by acid cleaning. Failure to adhere to the guidelines in the water quality table could result in the loss of warranty.

Material		Copper	90/10 Cupronickel	316 Stainless Steel
pH	Acidity/Alkalinity	7 - 9	7 - 9	7 - 9
Scaling	Calcium and Magnesium Carbonate	(Total Hardness) less than 350 ppm	(Total Hardness) less than 350 ppm	(Total Hardness) less than 350 ppm
Corrosion	Hydrogen Sulfide	Less than 0.5 ppm (rotten egg smell appears at 0.5 ppm)	10 - 50 ppm	Less than 1 ppm
	Sulfates	Less than 125 ppm	Less than 125 ppm	Less than 200 ppm
	Chlorine	Less than 0.5 ppm	Less than 0.5 ppm	Less than 0.5 ppm
	Chlorides	Less than 20 ppm	Less than 125 ppm	Less than 300 ppm
	Carbon Dioxide	Less than 50 ppm	10 - 50 ppm	10 - 50 ppm
	Ammonia	Less than 2 ppm	Less than 2 ppm	Less than 20 ppm
	Ammonia Chloride	Less than 0.5 ppm	Less than 0.5 ppm	Less than 0.5 ppm
	Ammonia Nitrate	Less than 0.5 ppm	Less than 0.5 ppm	Less than 0.5 ppm
	Ammonia Hydroxide	Less than 0.5 ppm	Less than 0.5 ppm	Less than 0.5 ppm
	Ammonia Sulfate	Less than 0.5 ppm	Less than 0.5 ppm	Less than 0.5 ppm
	Total Dissolved Solids (TDS)	Less than 1000 ppm	1000 - 1500 ppm	1000 - 1500 ppm
	LSI Index	+0.5 to -0.5	+0.5 to -0.5	+0.5 to -0.5
Iron Fouling (Biological Growth)	Iron, FE ²⁺ (Ferrous) Bacterial Iron Potential	< 0.2 ppm	< 0.2 ppm	< 0.2 ppm
	Iron Oxide	Less than 1 ppm, above this level deposition will occur	Less than 1 ppm, above this level deposition will occur	Less than 1 ppm, above this level deposition will occur
Erosion	Suspended Solids	Less than 10 ppm and filtered for max. of 600 micron size	Less than 10 ppm and filtered for max. of 600 micron size	Less than 10 ppm and filtered for max. of 600 micron size
	Threshold Velocity (Fresh Water)	< 1.8 m/sec	< 1.8 m/sec	< 1.8 m/sec

NOTES: Grains = ppm divided by 17
mg/L is equivalent to ppm

2/22/12

Vertical Dimensional Data

Top Air Discharge

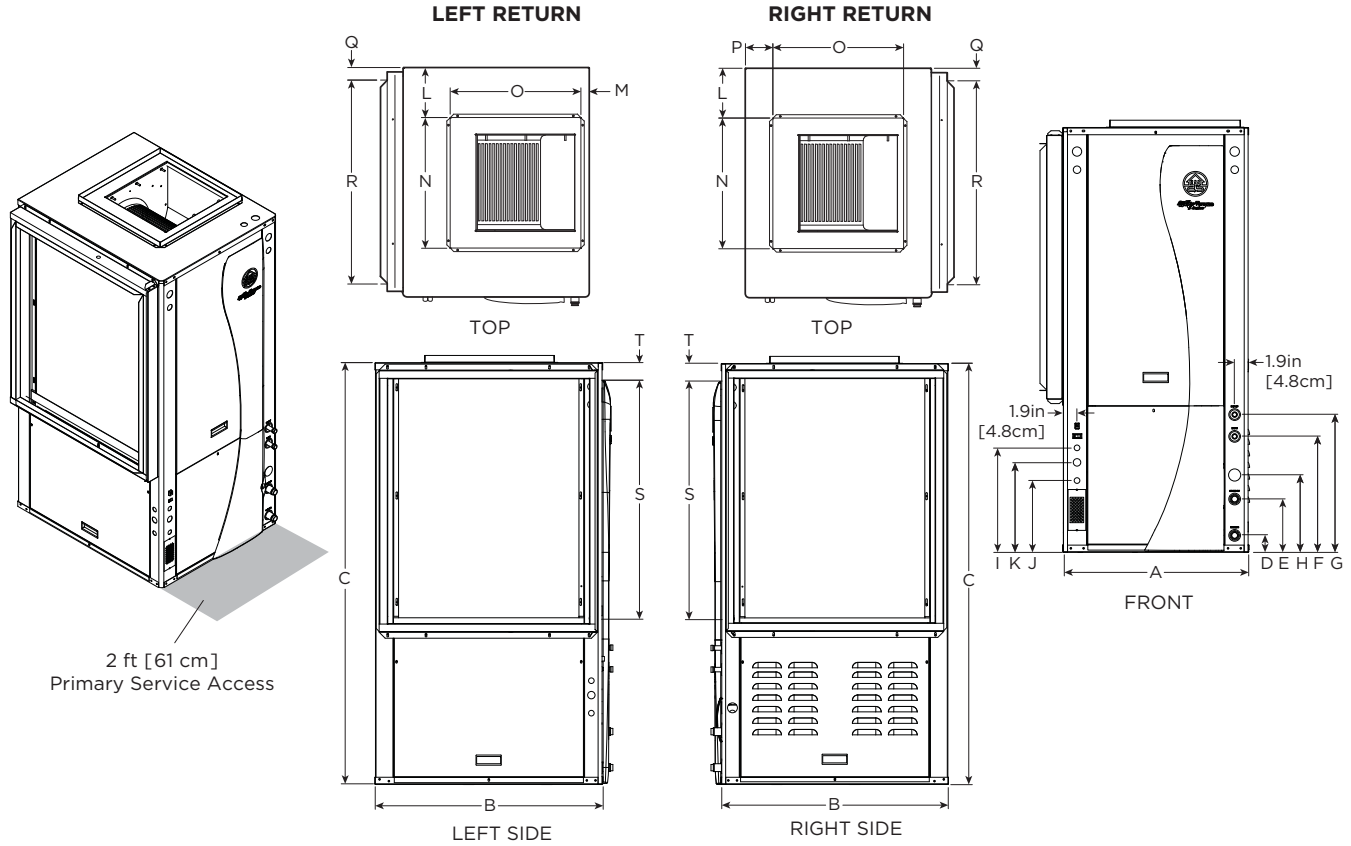

Vertical Top Flow Model	Overall Cabinet			Water Connections							Electrical Connections			Discharge Connection duct flange installed (± 2.54 mm)				Return Connection using std deluxe filter rack (± 2.54 mm)				
	A Width	B Depth	C Height	D Loop In	E Loop Out	F HWG In	G HWG Out	H Condensate	Loop Water FPT	HWG Sweat (I.D.)	I 12.7mm cond Low Voltage	J 12.7mm cond Ext Pump	K 19.05mm cond Power Supply	L	M	N Supply Width	O Supply Depth	P	Q	R Return Depth	S Return Height	T
009	cm.	65.0	80.3	138.2	5.8	18.5	40.4	48.0	26.9		36.3	24.9	31.2	17.5	2.8	45.7	45.7	9.7	4.3	71.4	76.2	4.3
012	cm.	65.0	80.3	138.2	5.8	18.5	40.4	48.0	26.9	25.4mm Swivel	36.3	24.9	31.2	17.5	2.8	45.7	45.7	9.7	4.3	71.4	76.2	4.3
015	cm.	65.0	80.3	148.3	5.8	18.5	40.4	48.0	26.9		36.3	24.9	31.2	17.5	2.8	45.7	45.7	9.7	4.3	71.4	86.4	4.3

Condensate is 19.05mm PVC female glue socket and is switchable from side to front
 Unit shipped with deluxe 5.08cm. (field adjustable to 2.54cm) duct collar/filter rack extending from unit 8.255cm and is suitable for duct connection.
 Discharge flange is field installed and extends 2.54cm from cabinet
 Decorative molding and/or water connections extend 30.5mm beyond front of cabinet.
 Louvered vents in the compressor section right side access panel extend 12.7 mm from side of cabinet. Allow clearance for venting.

5/22/13

Vertical Dimensional Data cont.

Bottom Air Discharge

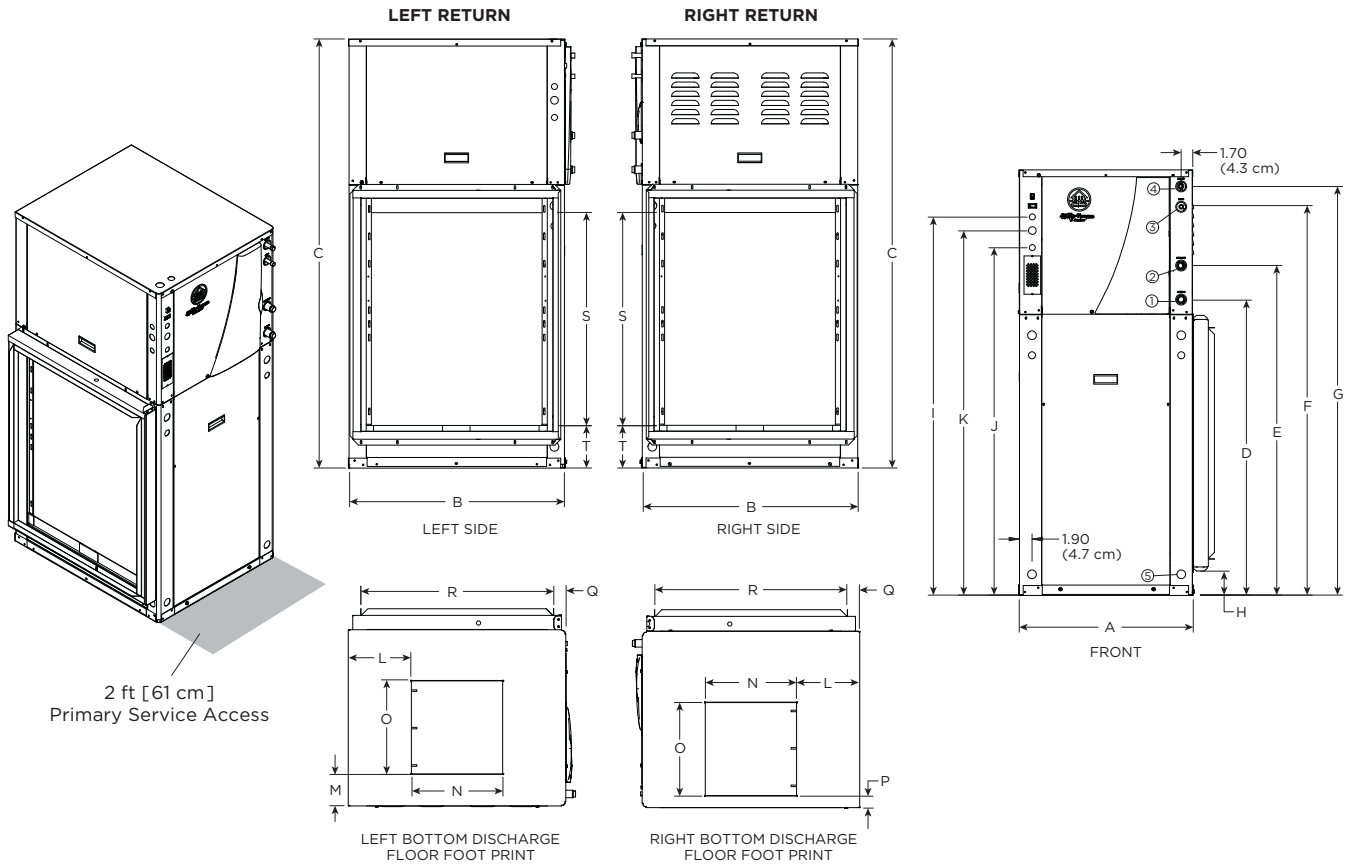

Bottomflow Models	Overall Cabinet			Water Connections							Electrical Knockouts			Discharge Connection duct flange installed (± 2.54mm)					Return Connection using std deluxe filter rack (± 2.54mm)				
				1	2	3	4	5	Loop Water FPT	HWG Sweat (I.D.)	I 12.7mm cond	J 12.7mm cond	K 19.05mm cond	L	M	N Supply Width	O Supply Depth	P	Q	R Return Depth	S Return Height	T	
	D In	E Out	F HWG In	G HWG Out	H Condensate	Low Voltage	Ext Pump	Power Supply															
009-015	cm.	64.8	80.0	158.8	110.2	122.9	144.8	152.4	7.9	25.4mm Swivel	12.7mm Female	129.8	141.2	136.1	23.1	12.2	34.0	34.5	4.3	4.6	71.4	86.4	14.2

Condensate is 19.05mm PVC female glue socket and is switchable from side to front
 Unit shipped with deluxe 5.08cm (field adjustable to 2.54cm) duct collar/filter rack extending from unit 8.255cm and is suitable for duct connection.
 Decorative molding and/or water connections extend 30.5mm beyond front of cabinet.
 Louvered vents in the compressor section right side access panel extend 12.7mm from side of cabinet. Allow clearance for venting.

5/29/13

Vertical Dimensional Data cont.

Rear Air Discharge

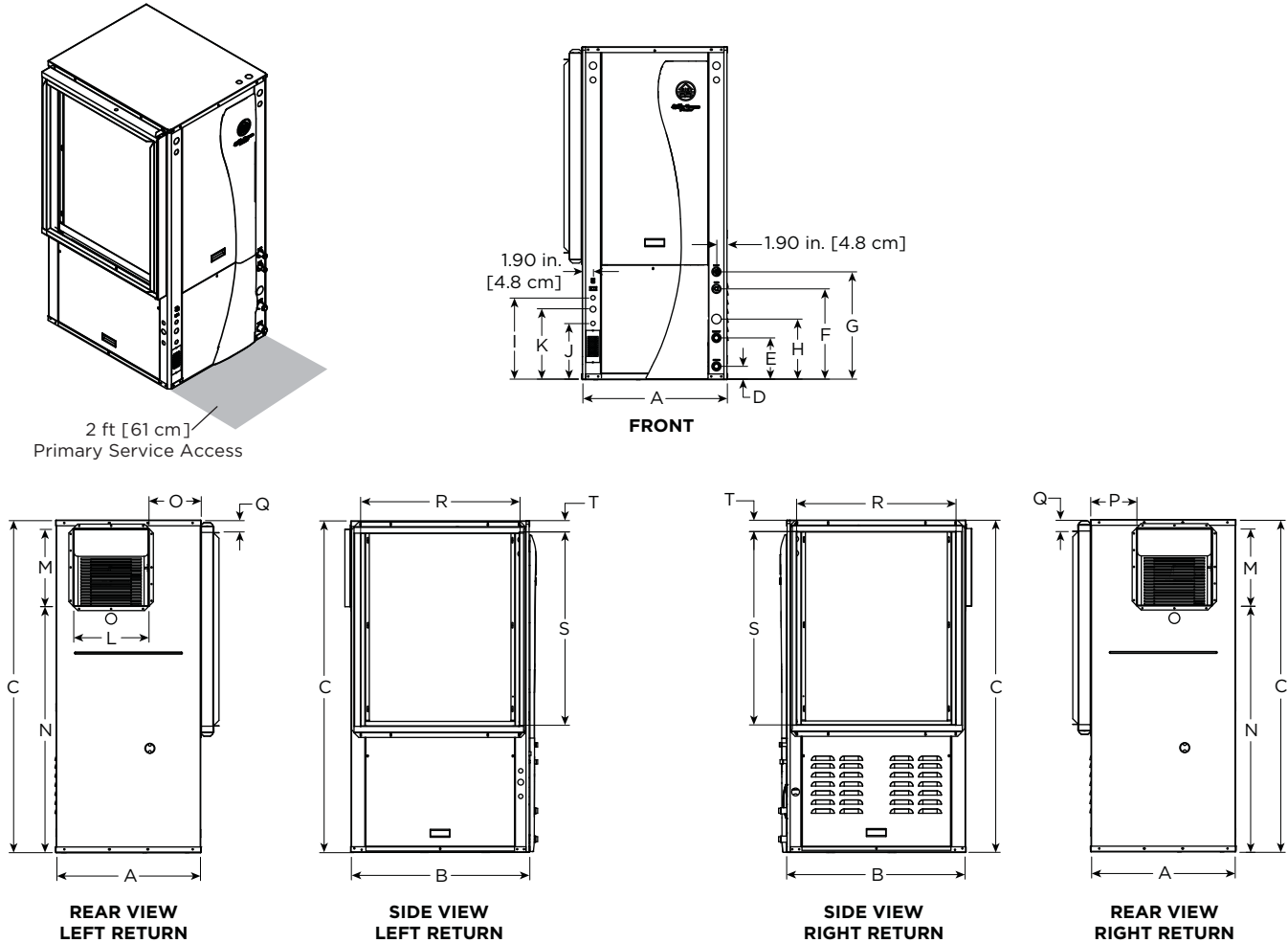

Vertical Rear Discharge Model	Overall Cabinet			Water Connections							Electrical Connections			Discharge Connection duct flange installed (± 2.54mm)					Return Connection using std deluxe filter rack (± 2.54mm)				
	A	B	C	D	E	F	G	H	Loop Water FPT	HWG Sweat (I.D.)	I	J	K	L	M	N	O	P	Q	R	S	T	
	Width	Depth	Height	Loop In	Loop Out	HWG In	HWG Out	Condensate			12.7mm cond Low Voltage	12.7mm cond Ext Pump	19.05mm cond Power Supply	Supply Width	Supply Depth				Return Depth	Return Height			
009	cm.	65.0	80.3	138.2	5.8	18.5	40.4	48.0	26.9			36.3	24.9	31.2	33.8	34.5	100.1	23.1	20.6	4.3	71.4	76.2	4.3
012	cm.	65.0	80.3	138.2	5.8	18.5	40.4	48.0	26.9	25.4mm Swivel	12.7mm Female	36.3	24.9	31.2	33.8	34.5	100.1	23.1	20.6	4.3	71.4	76.2	4.3
015	cm.	65.0	80.3	148.3	5.8	18.5	40.4	48.0	26.9			36.3	24.9	31.2	33.8	34.5	110.2	23.1	20.6	4.3	71.4	86.4	4.3

Condensate is 19.05mm PVC female glue socket and is switchable from side to front
 Unit shipped with deluxe 5.08cm (field adjustable to 2.54cm) duct collar/filter rack extending from unit 8.255cm and is suitable for duct connection.
 Discharge flange is field installed and extends 25.4mm from cabinet
 Decorative molding and/or water connections extend 30.5mm beyond front of cabinet.
 Louvered vents in the compressor section right side access panel extend 12.7 mm from side of cabinet. Allow clearance for venting.

5/29/13

Horizontal Dimensional Data

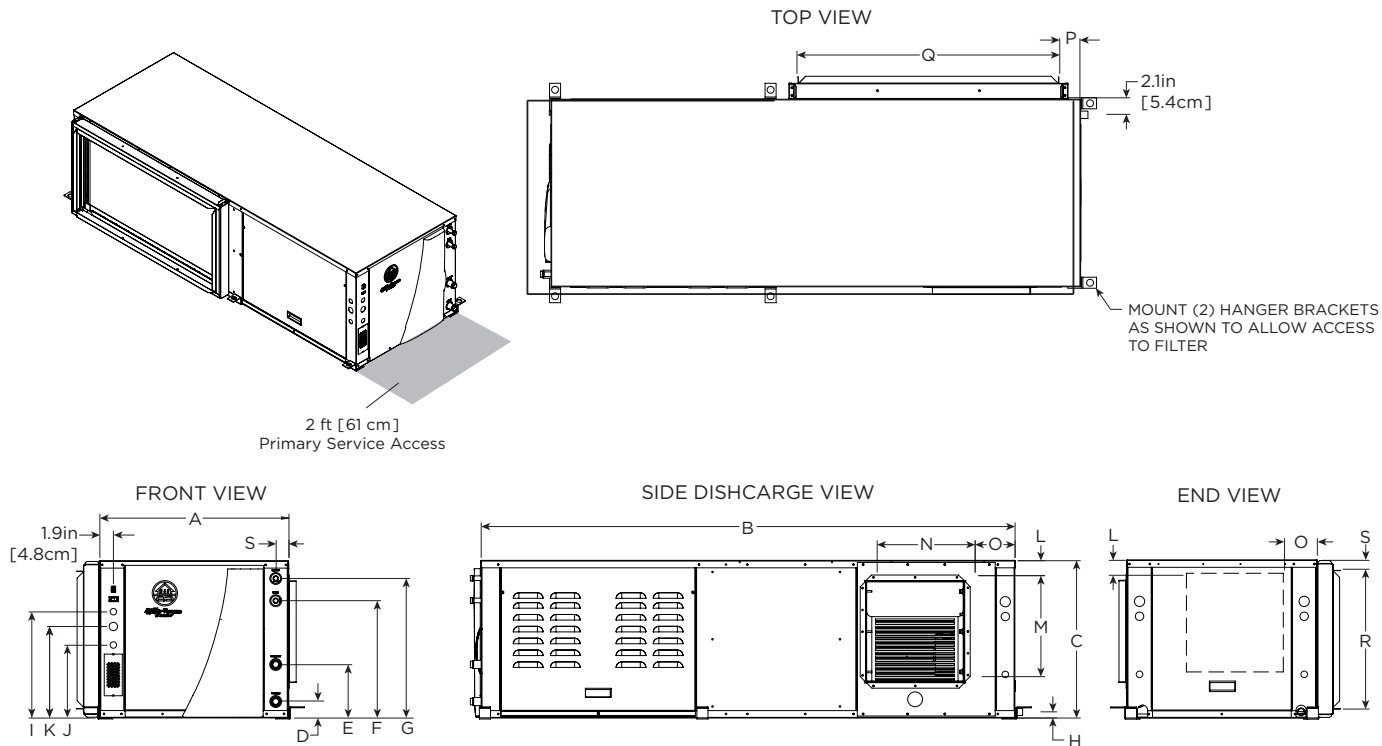

AS SHOWN LR UNIT (RR UNIT ON OPPOSITE SIDE—SAME DIMENSIONS)

Horizontal Models	Overall Cabinet			Water Connections								Electrical Connections			Discharge Connection duct flange installed (± 2.54mm)				Return Connection using std deluxe filter rack (± 2.54mm)			
	A	B	C	D	E	F	G	H	Loop Water FPT	HWG Sweat (I.D.)	I	J	K	L	M	N	O	P	Q	R	S	
	Width	Depth	Height	In	Out	HWG In	HWG Out	Condensate			12.7mm cond	12.7mm cond	19.05mm cond		Supply Height	Supply Depth		Return Depth	Return Height			
009	cm.	65.0	195.6	54.1	5.8	18.5	40.4	48.0	2.0		36.3	24.9	31.2	See Chart	34.5	33.5	See Chart	7.1	102.6	48.0	3.3	
012	cm.	65.0	195.6	54.1	5.8	18.5	40.4	48.0	2.0		36.3	24.9	31.2		34.5	33.5		7.1	102.6	48.0	3.3	
015	cm.	65.0	208.3	54.1	5.8	18.5	40.4	48.0	2.0	25.4mm Swivel	36.3	24.9	31.2		34.5	33.5		7.1	115.3	48.0	3.3	

Condensate is 19.05mm PVC female glue socket and is switchable from side to front
 Unit shipped with deluxe 5.08cm (field adjustable to 2.54cm) duct collar/filter rack extending from unit 8.255cm and is suitable for duct connection.
 Discharge flange is field installed and extends 25.4mm from cabinet
 Decorative molding and/or water connections extend 30.5mm beyond front of cabinet.
 Louvered vents in the compressor section right side access panel extend 12.7 mm from side of cabinet. Allow clearance for venting.

Units Not Shown Above		L	O
Right Return End Discharge	cm	7.1	11.8
Right Return Side Discharge	cm	12.4	17.5
Left Return End Discharge	cm	12.4	19.4
Left Return Side Discharge	cm	7.1	17.5

Physical Data

Model		Variable Speed		
		009	012	015
Compressor (1 each)		Variable Speed Scroll		
Factory Charge R-410A, kg Vertical		2.69	3.40	3.96
Factory Charge R-410A, kg Horizontal		2.69	3.85	4.19
ECM Blower Motor & Blower				
Blower Motor Type/Speeds	ECM	Variable Speed		
Blower Motor - W	ECM	373	746	746
High Static Blower Motor - W	ECM	746	N/A	N/A
Blower Wheel Size (Dia x W), mm	ECM	279 x 254	279 x 254	279 x 254
High Static Blower Wheel Size - [Dia. x W], mm	ECM	279 x 254	N/A	N/A
Coax and Water Piping				
Water Connections Size - Swivel - in [mm]		1 [25.4]	1 [25.4]	1 [25.4]
HWG Connection Size - Female Sweat I.D. - in [mm]		1/2 [12.7]	1/2 [12.7]	1/2 [12.7]
Coax & Piping Water Volume - l		6.1	6.1	8.7
Vertical				
Air Coil Dimensions (H x W), mm		813 x 635	813 x 635	914 x 635
Air Coil Total Face Area, m ²		0.570	0.570	0.641
Air Coil Tube Size, mm		9.5	9.5	9.5
Air Coil Number of rows		3	3	4
Filter Standard - 51 mm Pleated MERV 11 Throwaway, mm		813 x 762	813 x 762	914 x 762
Weight - Operating, kg		160	164	175
Weight - Packaged, kg		169	173	184
Horizontal				
Air Coil Dimensions (H x W), mm		508 x 1016	508 x 1016	508 x 1143
Air Coil Total Face Area, m ²		0.570	0.570	0.641
Air Coil Tube Size, mm		9.5	9.5	9.5
Air Coil Number of rows		3	3	4
Filter Standard - 51 mm Pleated MERV 11 Throwaway, mm		1 - 508 x 508 1 - 508 x 559	1 - 508 x 508 1 - 508 x 559	1 - 508 x 635 1 - 508 x 559
Weight - Operating, kg		176	180	188
Weight - Packaged, kg		189	193	202

5/13/13

Auxiliary Heat Ratings

Model	kW		Stages	Min L/s	Model Compatibility		
	208V	230V			009	012	015
EAL(H)10	7.2	9.6	2	519	•	•	•
EAL(H)15	10.8	14.4	3	590	•	•	•
EAL(H)20	14.4	19.2	4	708		•	•

Air flow level for auxiliary heat (Aux) must be above the minimum air flow in this table
Order the "H" part number when installed on horizontal and vertical rear discharge units

7/17/13

Auxiliary Heat Electrical Data

Model	Supply Circuit	Heater Amps		Min Circuit Amp		Max Fuse (USA)		Max Fuse (CAN)		Max CKT BRK	
		208 V	240 V	208 V	240 V	208 V	240 V	208 V	240 V	208 V	240 V
EAL(H)10	Single	34.7	40	53.3	60	60	60	60	60	60	60
EAL(H)15	Single	52.0	60	75	85	80	90	80	90	70	100
	L1/L2	34.7	40	53.3	60	60	60	60	60	60	60
	L3/L4	17.3	20	21.7	25	25	25	25	25	20	30
EAL(H)20	Single	69.3	80	96.7	110	100	110	100	110	100	100
	L1/L2	34.7	40	53.3	60	60	60	60	60	60	60
	L3/L4	34.7	40	43.3	50	45	50	45	50	40	50

All heaters rated single phase 60 cycle and include unit fan load
All fuses type "D" time delay (or HACR circuit breaker in USA)

6/1/12

Electrical Data

Model	Rated Voltage	Voltage Min/Max	Compressor		Drive		HWG Pump FLA	Ext Loop FLA	Blower Motor FLA	Total Unit FLA	Minimum Circuit Amp	Max Fuse HACR Breaker
			LRA	CMCC	LRA	Internal Breaker						
009	220-240/50/1	198/264	10.2	18.0	22.0	30.0	0.4	5.4	4.0	31.8	37.3	40
*009	220-240/50/1	198/264	10.2	18.0	22.0	30.0	0.4	5.4	7.0	34.8	40.3	45
012	220-240/50/1	198/264	12.0	23.5	28.0	35.0	0.4	5.4	7.0	40.8	47.8	50
015	220-240/50/1	198/264	12.0	30.0	33.0	40.0	0.4	5.4	7.0	45.8	54.1	60

*With optional 1 hp Variable Speed ECM Motor
 Rated Voltage of 220-240/50/1
 HACR circuit breaker in USA only
 All fuses Class RK-5

5/08/13

Blower Performance Data

Variable Speed ECM Blower Motor

Model	Max ESP (Pa)	Air Flow											
		Speed 1	Speed 2	Speed 3	Speed 4	Speed 5	Speed 6	Speed 7	Speed 8	Speed 9	Speed 10	Speed 11	Speed 12
009	124.50	135	179 G	248 L	319	385	463	519	576	628	680 H	727 Aux	743
009 w/746W*	186.75	227	267 G	314 L	359	411	472	519	566	614	665 H	717 Aux	769
012	186.75	224	293 G	345 L	401	481	538	599	661	717	779 H	845 Aux	908
015	186.75	189	283 G	392 L	496	580	661	736	802	883	949 H	1010 Aux	1069
**VS Compressor Speed				1-2	3-4		5-6	7-8		9-10	11-12		

5/13/13

** VS Compressor speed is given for the factory default L/s settings. When the L/s default settings are changed it will change the relationship to the compressor speed that is shown in the table. In cooling mode compressor speeds 10-12 are only available when SuperBoost mode is selected at the thermostat.

* Optional 746W Variable Speed ECM

Factory settings are at recommended L , H and Aux positions

"G" may be located anywhere within the airflow table

"L" setting should be located within the boldface L/s range

"H" setting MUST be located within the shaded L/s range

"Aux" setting MUST be equal to or greater than "H" setting

"Aux" setting MUST be equal to or greater than the minimum allowable L/s for the auxiliary heater kit (see auxiliary heat ratings table)

Cfm is controlled within 5% up to the maximum ESP

Max ESP includes allowance for wet coil and standard filter

Setting Blower Speed - Variable speed ECM

The ABC board's Yellow Config LED will flash the current ECM blower speed selections for G, low, and high continuously with a short pause in between. The speeds can also be confirmed with the AID Tool under the Setup/ECM Setup screen. The Aux will not be flashed but can be viewed in the AID Tool. The ECM blower motor speeds can be field adjusted with or without using an AID Tool.

Variable speed ECM Setup without an AID Tool

The blower speeds for G only, Low (Y1), and High (Y2/Aux) can be adjusted directly at the Aurora ABC board which utilizes the push button (SW1) on the ABC board. This procedure is outlined in the ECM Configuration Mode portion of the Aurora 'Base' Control System section. The Aux cannot be set manually without an AID Tool.

Variable speed ECM Setup with an AID Tool

A much easier method utilizes the AID Tool to change the airflow using the procedure below. First navigate to the Setup screen and then select ECM Setup. This screen displays the current ECM settings. It allows the technician to enter the setup screens to change the ECM settings. Change

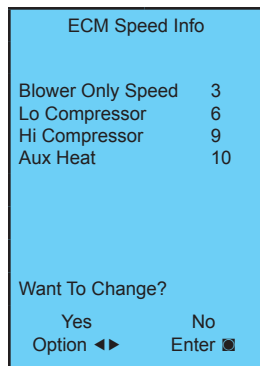

the highlighted item using the ◀ and ▶ buttons and then press the ■ button to select the item.

Selecting YES will enter ECM speed setup, while selecting NO will return to the previous screen.

ECM Speed Setup - These screens allow the technician to select the G, low, high, and auxiliary heat blower speed for the ECM blower motor. Change the highlighted item using the ▲ and ▼ buttons. Press the ■ button to select the speed.

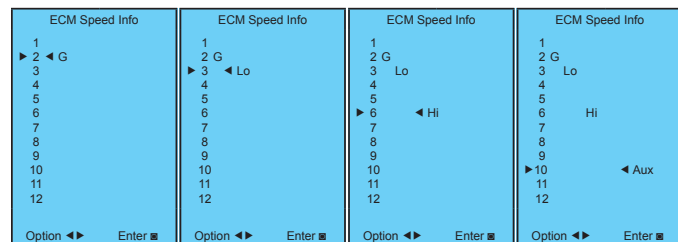

After the auxiliary heat speed setting is selected the AID Tool will automatically transfer back to the ECM Setup screen.

Cooling Airflow Setup - These screens allow the technician to select -15%, -10%, -5%, None or +5% change from the heating airflow. Change the adjustment percentage using the ▲ and ▼ buttons. Press the ■ button to save the change.

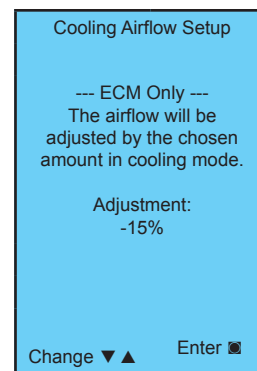
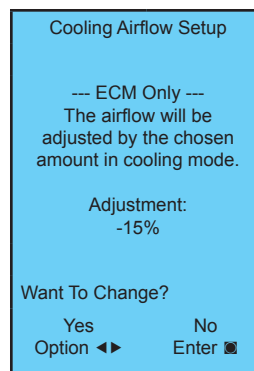

Reference Calculations

Heating Calculations:	Cooling Calculations:
$LWT = EWT - \frac{HE}{WF \times 500}$	$LWT = EWT + \frac{HR}{WF \times 500}$
$LAT = EAT + \frac{HC}{AF \times 1.08}$	$LAT (DB) = EAT (DB) - \frac{SC}{AF \times 1.08}$
$TH = HC + HW$	$LC = TC - SC$
	$S/T = \frac{SC}{TC}$

NOTE: * When using water. Use 4.1 for 15% methanol/water or Environol solution.

Legend

ABBREVIATIONS AND DEFINITIONS:

COP = coefficient of performance
 EER = cooling energy efficiency (TC/kW)
 ELT = entering load fluid temperature
 EST = entering source fluid temperature to heat pump
 FLA = full load amps
 FtHd = pressure drop in feet of head
 gpm = US gallon per minute
 HC = heating capacity in kW
 HE = heat of extraction in kW
 HR = heat rejected in kW
 kPa = kilopascal
 kW = kilowatt

L/s = liters per second
 LLT = leaving load fluid temperature from heat pump
 LRA = locked rotor amps (starting current)
 LST = leaving source fluid temperature from heat pump
 LWPD= load heat exchanger water pressure drop
 MCC = maximum continuous current
 PD = pressure drop
 psi = pressure drop in pounds per square inch
 P/T = Pressure/Temperature
 RLA = run load amps
 TC = total cooling capacity in kW
 W = Watt

CONVERSIONS:

$x^{\circ}F = (x - 32)/1.8^{\circ}C$
 1 bar = 100 kPa
 1 gpm= 0.0631 L/s

1 US Gallon = 3.785412 L
 1 Btu/h = 0.29037 W

Operating Limits

Operating Limits	Cooling (°C)	Heating (°C)
Air Limits		
Min. Ambient Air	7.2	7.2
Rated Ambient Air	26.7	21.1
Max. Ambient Air	37.8	29.4
Min. Entering Air	10.0	4.4
Rated Entering Air db/wb	27/19	20.0
Max. Entering Air db/wb	43/28.3	26.7
Water Limits		
Min. Entering Water	-1.1	-6.7
Normal Entering Water	10-43.3	-1.1
Max. Entering Water	48.9	32.2

NOTE: Minimum/maximum limits are only for startup conditions, and are meant for bringing the space up to occupancy temperature. Units are not designed to operate at the minimum/maximum conditions on a regular basis. The operating limits are dependent upon three primary factors: 1) water temperature, 2) return air temperature, and 3) ambient temperature. When any of the factors are at the minimum or maximum levels, the other two factors must be at the normal level for proper and reliable unit operation.

Antifreeze Corrections

Catalog performance can be corrected for antifreeze use. Please use the following table and note the example given.

Antifreeze Type	Antifreeze % by wt	Heating		Cooling		Pressure Drop
		Load	Source	Load	Source	
EWT - °C		26.7	-1.1	10.0	32.2	-1.1
Water	0	1.000	1.000	1.000	1.000	1.000
Ethylene Glycol	10	0.990	0.973	0.976	0.991	1.075
	20	0.978	0.943	0.947	0.979	1.163
	30	0.964	0.917	0.921	0.965	1.225
	40	0.953	0.890	0.897	0.955	1.324
	50	0.942	0.865	0.872	0.943	1.419
Propylene Glycol	10	0.981	0.958	0.959	0.981	1.130
	20	0.967	0.913	0.921	0.969	1.270
	30	0.946	0.854	0.869	0.950	1.433
	40	0.932	0.813	0.834	0.937	1.614
	50	0.915	0.770	0.796	0.922	1.816
Ethanol	10	0.986	0.927	0.945	0.991	1.242
	20	0.967	0.887	0.906	0.972	1.343
	30	0.944	0.856	0.869	0.947	1.383
	40	0.926	0.815	0.830	0.930	1.523
	50	0.907	0.779	0.795	0.911	1.639
Methanol	10	0.985	0.957	0.962	0.986	1.127
	20	0.969	0.924	0.929	0.970	1.197
	30	0.950	0.895	0.897	0.951	1.235
	40	0.935	0.863	0.866	0.936	1.323
	50	0.919	0.833	0.836	0.920	1.399



WARNING: Gray area represents antifreeze concentrations greater than 35% by weight and should be avoided due to the extreme performance penalty they represent.

Antifreeze Correction Example

Antifreeze solution is Propylene Glycol 20% by weight. Determine the corrected heating and cooling performance at -1.1°C and 32.2°C respectively as well as pressure drop at -1.1°C for a NVK036 operating at 100% capacity.

The corrected cooling capacity at 32.2°C would be: 10.3 kW x 0.969 = 10.0 kW

The corrected heating capacity at -1.1°C would be: 11.0 kW x 0.913 = 10.0 kW

The corrected pressure drop at -1.1°C and 0.7 L/s would be: 23.50 kPa x 1.270 = 29.85 kPa

Notes

Notes (Refer to Performance Data tables)

- Performance ratings are based on 27°C DB / 19°C WB EAT for cooling and 20°C DB EAT for heating.
- Three flow rates are shown for each unit. The lowest flow rate shown is used for geothermal open loop/well water systems with a minimum of 10°C EWT. The middle flow rate shown is the minimum geothermal closed loop flow rate. The highest flow rate shown is optimum for geothermal closed loop systems and the suggested flow rate for boiler/tower applications.
- The hot water generator numbers are based on a flow rate of 7.16 ml/s per kW of rated capacity with an EWT of 32°C.
- Entering water temperatures below 4.5°C assumes 15% antifreeze solution.
- For non-standard EAT conditions, apply the appropriate correction factors on (Refer to Correction Factor Tables).
- Interpolation between EWT, WF and AF data is permissible.

Pressure Drop

Model	L/s	Pressure Drop (kPa)				
		-1.1°C	10.0°C	21.1°C	32.2°C	43.3°C
009	0.7	23.44	22.06	20.68	19.31	17.93
	0.6	18.62	17.93	16.55	15.17	14.48
	0.4	11.38	10.69	10.00	9.31	8.62
	0.3	7.58	6.89	6.21	5.86	5.17
	0.3	4.69	4.41	4.14	3.79	3.52
012	0.9	31.72	30.34	28.27	26.20	24.13
	0.7	19.99	18.62	17.24	15.86	15.17
	0.5	11.72	11.03	10.34	9.65	8.96
	0.4	8.27	7.58	6.89	6.62	6.27
	0.3	4.27	4.21	4.14	4.00	3.86
015	1.1	44.13	41.37	38.61	35.85	33.09
	0.9	28.27	26.20	24.82	22.75	21.37
	0.6	15.17	14.48	13.79	12.41	11.72
	0.5	11.72	11.03	10.34	9.65	8.96
	0.3	4.69	4.27	4.00	3.79	3.65

5/22/13

Correction Factor Tables

Air Flow Corrections (Compressor Speeds 1-3)

Airflow		Cooling				Heating		
L/s Per kW of Clg	% of Nominal	Total Cap	Sens Cap	Power	Heat of Rej	Htg Cap	Power	Heat of Ext
32	60	0.940	0.740	0.967	0.951	0.943	1.106	0.902
37	69	0.950	0.783	0.973	0.959	0.953	1.088	0.918
40	75	0.960	0.827	0.978	0.967	0.962	1.070	0.935
44	81	0.970	0.870	0.984	0.975	0.972	1.053	0.951
47	88	0.980	0.913	0.989	0.984	0.981	1.035	0.967
50	94	0.990	0.957	0.995	0.992	0.991	1.018	0.984
54	100	1.000	1.000	1.000	1.000	1.000	1.000	1.000
57	106	1.030	1.022	1.024	1.026	1.009	0.982	1.016
61	113	1.060	1.045	1.048	1.051	1.019	0.965	1.033
64	119	1.091	1.067	1.071	1.077	1.028	0.947	1.049
67	125	1.121	1.089	1.095	1.103	1.038	0.930	1.065
70	130	1.151	1.111	1.110	1.129	1.047	0.912	1.082

5/29/13

Air Flow Corrections (Compressor Speeds 4-12)

Airflow		Cooling				Heating		
L/s Per kW of Clg	% of Nominal	Total Cap	Sens Cap	Power	Heat of Rej	Htg Cap	Power	Heat of Ext
32	60	0.928	0.747	0.936	0.929	0.961	1.097	0.938
37	69	0.940	0.789	0.946	0.941	0.967	1.081	0.948
40	75	0.952	0.831	0.957	0.953	0.974	1.064	0.959
44	81	0.964	0.873	0.968	0.965	0.980	1.048	0.969
47	88	0.976	0.916	0.979	0.976	0.987	1.032	0.979
50	94	0.988	0.958	0.989	0.988	0.993	1.016	0.990
54	100	1.000	1.000	1.000	1.000	1.000	1.000	1.000
57	106	1.020	1.023	1.004	1.018	1.010	0.966	1.018
61	113	1.056	1.042	1.008	1.035	1.020	0.932	1.036
64	119	1.072	1.079	1.011	1.053	1.029	0.898	1.054
67	125	1.087	1.095	1.015	1.070	1.039	0.865	1.071
70	130	1.099	1.113	1.019	1.088	1.049	0.831	1.089

5/29/13

Cooling Capacity Corrections

Entering Air WB °C	Total Clg Cap	Sensible Cooling Capacity Multipliers - Entering DB °C										Power Input	Heat of Rejection
		15.6	18.3	21.1	23.9	26.7	27.0	29.4	32.2	35.0	37.8		
12.8	0.898	0.723	0.866	1.048	1.185	*	*	*	*	*	*	0.985	0.913
15.6	0.912		0.632	0.880	1.078	1.244	1.260	*	*	*	*	0.994	0.927
17.2	0.945			0.768	0.960	1.150	1.175	*	*	*	*	0.996	0.954
18.3	0.976			0.694	0.881	1.079	1.085	1.270	*	*	*	0.997	0.972
19.0	0.983			0.655	0.842	1.040	1.060	1.232	*	*	*	0.999	0.986
19.4	1.000			0.616	0.806	1.000	1.023	1.193	1.330	1.480	*	1.000	1.000
21.1	1.053				0.693	0.879	0.900	1.075	1.205	1.404	*	1.003	1.044
23.9	1.168					0.687	0.715	0.875	1.040	1.261	1.476	1.007	1.141

NOTE: *Sensible capacity equals total capacity at conditions shown.

5/13/13

Heating Capacity Corrections

Ent Air DB °C	Heating Corrections		
	Htg Cap	Power	Heat of Ext
7.2	1.062	0.739	1.158
10.0	1.050	0.790	1.130
12.8	1.037	0.842	1.096
15.6	1.025	0.893	1.064
18.3	1.012	0.945	1.030
20.0	1.005	0.976	1.012
21.1	1.000	1.000	1.000
23.9	0.987	1.048	0.970
26.7	0.975	1.099	0.930

5/13/13

Performance Data

NVK009 - 50% Part Load

EWT °C	Flow L/s	WPD kPa	HEATING - EAT 21.1°C							EWT °C	Flow L/s	WPD kPa	COOLING - EAT 26.7/19.4°C							
			Airflow L/s	HC kW	Power kW	HE kW	LAT °C	COP	HWC kW				Airflow L/s	TC kW	SC kW	S/T Ratio	Power kW	HR kW	EER	HWC kW
-6.7	0.2	2.10	Operation not recommended							-6.7	0.2	1.05	Operation not recommended							
	0.3	4.80	Operation not recommended								0.2	3.19	Operation not recommended							
	0.3	7.50	259.6	4.2	1.24	3.0	34.6	3.41	0.6		0.3	5.32	Operation not recommended							
-1.1	0.2	2.04	259.6	4.8	1.30	3.5	36.5	3.71	0.7	-1.1	0.2	1.02	236	6.8	4.46	0.65	0.49	7.32	13.8	-
		354	4.9	1.32	3.6	32.6	3.69	0.6	306.8			6.7	4.42	0.66	0.55	7.23	12.3	-		
	0.3	4.66	259.6	5.1	1.34	3.7	37.3	3.79	0.8		0.2	3.09	236	6.8	4.46	0.65	0.48	7.30	14.3	-
		354	5.2	1.35	3.8	33.2	3.84	0.6	306.8			6.6	4.59	0.69	0.58	7.18	11.4	-		
	0.3	7.28	259.6	5.2	1.35	3.8	37.6	3.84	0.8		0.3	5.17	236	6.9	4.59	0.66	0.47	7.41	14.7	-
			354	5.2	1.36	3.9	33.4	3.86	0.7				306.8	6.7	4.54	0.68	0.54	7.25	12.4	-
4.4	0.2	1.98	259.6	5.4	1.35	4.1	38.4	4.03	0.7	4.4	0.2	0.99	236	7.0	4.60	0.65	0.57	7.59	12.4	-
		354	5.5	1.36	4.2	34.0	4.06	0.6	306.8			7.0	4.69	0.67	0.63	7.64	11.1	-		
	0.3	4.52	259.6	5.7	1.38	4.3	39.3	4.13	0.8		0.2	3.00	236	7.0	4.60	0.65	0.55	7.58	12.9	-
			354	5.8	1.38	4.4	34.7	4.20	0.7				306.8	7.0	4.79	0.69	0.64	7.61	10.9	-
	0.3	7.07	259.6	5.8	1.39	4.4	39.6	4.15	0.8		0.3	5.02	236	7.1	4.65	0.65	0.54	7.66	13.1	-
			354	5.9	1.39	4.5	34.9	4.23	0.7				306.8	7.1	4.77	0.68	0.61	7.66	11.7	-
10.0	0.2	1.91	259.6	6.0	1.45	4.6	40.3	4.16	0.8	10.0	0.2	0.96	236	7.1	4.75	0.67	0.59	7.68	11.9	-
		354	6.1	1.45	4.7	35.5	4.24	0.7	306.8			7.1	4.93	0.69	0.66	7.77	10.7	-		
	0.3	4.38	259.6	6.3	1.48	4.8	41.3	4.27	0.9		0.2	2.91	236	7.1	4.76	0.67	0.57	7.67	12.4	-
			354	6.4	1.48	5.0	36.2	4.36	0.7				306.8	7.1	4.98	0.70	0.65	7.76	10.9	-
	0.3	6.85	259.6	6.4	1.50	4.9	41.6	4.27	0.9		0.3	4.86	236	7.2	4.79	0.67	0.57	7.74	12.6	-
			354	6.6	1.49	5.1	36.5	4.41	0.8				306.8	7.2	4.98	0.69	0.62	7.80	11.6	-
15.6	0.2	1.85	259.6	6.8	1.42	5.3	42.7	4.75	0.9	15.6	0.2	0.93	236	6.6	4.53	0.69	0.70	7.28	9.4	0.3
		354	6.9	1.41	5.5	37.3	4.91	0.7	306.8			6.7	4.81	0.71	0.77	7.50	8.8	0.3		
	0.3	4.24	259.6	7.1	1.45	5.6	43.7	4.88	0.9		0.2	2.82	236	6.6	4.55	0.69	0.67	7.28	9.8	0.3
			354	7.2	1.44	5.8	38.1	5.03	0.8				306.8	6.8	4.83	0.71	0.75	7.51	9.1	0.3
	0.3	6.63	259.6	7.2	1.47	5.7	44.0	4.89	1.0		0.3	4.71	236	6.7	4.58	0.69	0.67	7.34	10.0	0.3
			354	7.4	1.45	5.9	38.3	5.08	0.8				306.8	6.8	4.86	0.71	0.72	7.52	9.5	0.3
21.1	0.2	1.79	259.6	7.4	1.35	6.1	44.8	5.48	0.9	21.1	0.2	0.90	236	6.2	4.59	0.74	0.84	7.07	7.4	0.4
		354	7.6	1.37	6.2	38.9	5.54	0.8	306.8			5.5	4.31	0.78	0.91	6.45	6.1	0.4		
	0.3	4.10	259.6	7.7	1.38	6.4	45.8	5.61	1.0		0.2	2.72	236	6.3	4.62	0.74	0.81	7.07	7.7	0.4
			354	8.0	1.36	6.6	39.8	5.86	0.8				306.8	6.6	4.99	0.76	0.88	7.44	7.5	0.4
	0.3	6.41	259.6	7.8	1.55	6.2	45.9	5.01	1.0		0.3	4.55	236	5.4	3.75	0.69	0.79	6.21	6.9	0.4
			354	8.1	1.37	6.7	40.0	5.91	0.9				306.8	6.6	5.04	0.77	0.85	7.41	7.7	0.4
26.7	0.2	1.73	259.6	8.0	1.43	6.5	46.5	5.57	1.0	26.7	0.2	0.87	236	5.9	4.40	0.75	0.97	6.82	6.0	0.6
		354	8.2	1.39	6.8	40.3	5.88	0.8	306.8			6.0	4.70	0.78	1.04	7.04	5.8	0.6		
	0.3	3.96	259.6	8.3	1.46	6.9	47.6	5.69	1.1		0.2	2.63	236	5.9	4.43	0.75	0.94	6.82	6.3	0.6
			354	8.6	1.43	7.2	41.2	6.03	0.9				306.8	6.1	4.70	0.77	0.99	7.06	6.1	0.6
	0.3	6.19	259.6	8.5	1.48	7.0	48.1	5.72	1.1		0.3	4.40	236	5.9	4.47	0.75	0.92	6.87	6.5	0.6
			354	8.7	1.44	7.3	41.5	6.07	0.9				306.8	6.1	4.75	0.78	0.96	7.06	6.3	0.7
32.2	0.2	1.67	259.6	8.5	1.44	7.1	48.3	5.92	1.1	32.2	0.2	0.83	236	5.4	4.19	0.77	1.11	6.53	4.9	0.8
		354	8.8	1.40	7.4	41.7	6.31	0.9	306.8			5.5	4.41	0.81	1.18	6.63	4.6	0.8		
	0.3	3.82	259.6	8.9	1.47	7.4	49.5	6.03	1.1		0.2	2.54	236	5.5	4.23	0.78	1.07	6.53	5.1	0.8
			354	9.2	1.42	7.8	42.7	6.47	0.9				306.8	5.5	4.41	0.80	1.11	6.63	5.0	0.8
	0.3	5.97	259.6	9.0	1.49	7.5	50.0	6.06	1.2		0.3	4.24	236	5.5	4.28	0.78	1.05	6.56	5.3	0.8
			354	9.4	1.44	7.9	43.1	6.51	1.0				306.8	5.6	4.45	0.80	1.08	6.65	5.2	0.8
37.8	0.2	1.61	Operation not recommended							37.8	0.2	0.80	236	5.2	4.04	0.78	1.39	6.55	3.7	0.9
	0.3	3.68									306.8	5.2	4.23	0.81	1.43	6.64	3.6	0.9		
	0.3	5.76									236	5.2	4.08	0.78	1.33	6.54	3.9	0.9		
43.3	0.2	1.55								43.3	0.2	0.77	306.8	5.3	4.26	0.81	1.36	6.62	3.9	0.9
													306.8	5.3	4.13	0.79	1.30	6.56	4.0	1.0
	0.3	3.54									2.35	306.8	5.3	4.30	0.81	1.33	6.64	4.0	1.0	
												236	4.3	3.70	0.86	1.56	5.88	2.8	0.9	
	0.3	5.54									3.93	306.8	4.4	3.85	0.88	1.57	5.94	2.8	0.9	
												236	4.4	3.91	0.89	1.51	5.92	2.9	1.0	
48.9	0.2	1.49								48.9	0.2	0.74	236	4.4	3.80	0.86	1.46	5.87	3.0	1.0
													306.8	4.5	3.96	0.89	1.47	5.92	3.0	1.0
	0.3	3.40									2.26	236	3.9	3.31	0.86	1.81	5.68	2.1	1.3	
												306.8	3.8	3.32	0.87	1.75	5.55	2.2	1.3	
	0.3	5.32									3.78	236	3.9	3.36	0.86	1.74	5.65	2.3	1.3	
												306.8	3.8	3.42	0.89	1.74	5.57	2.2	1.3	
0.3	5.32	3.78								236	4.0	3.50	0.88	1.67	5.65	2.4	1.3			
										306.8	3.9	3.46	0.89	1.69	5.59	2.3	1.3			

Performance Data cont.

NVK009 - 100% Full Load

EWT °C	Flow L/s	WPD kPa	HEATING - EAT 21.1°C							EWT °C	Flow L/s	WPD kPa	COOLING - EAT 26.7/19.4°C														
			Airflow L/s	HC kW	Power kW	HE kW	LAT °C	COP	HWC kW				Airflow L/s	TC kW	SC kW	S/T Ratio	Power kW	HR kW	EER	HWC kW							
-6.7	0.3	7.52	Operation not recommended										-6.7	0.3	4.83	Operation not recommended											
	0.5	18.56												0.4	11.70												
	0.7	24.20	542.8	9.3	2.84	6.4	35.2	3.26	1.4	708	9.5	2.87		6.7	32.3	3.32	1.3										
-1.1	0.3	7.31	542.8	10.3	2.74	7.6	36.9	3.77	1.5	708	10.5	2.79	7.7	33.4	3.78	1.4	-1.1	0.3	4.69	472	11.5	8.01	0.70	0.98	12.48	11.8	-
			542.8	10.4	2.77	7.7	37.0	3.77	1.6	708	10.6	2.82	7.8	33.6	3.77	1.4		472	11.5	7.99	0.70	0.95	12.44	12.2	-		
	0.5	18.02	542.8	10.6	2.92	7.7	37.3	3.62	1.6	708	11.0	2.89	8.1	33.9	3.79	1.5		0.4	11.36	472	11.1	8.23	0.74	1.14	12.27	9.7	-
			542.8	10.6	2.92	7.7	37.3	3.62	1.6	708	11.0	2.89	8.1	33.9	3.79	1.5		0.6	18.80	472	11.5	8.06	0.70	0.95	12.48	12.2	-
	0.7	23.50	542.8	12.0	2.73	9.3	39.4	4.40	1.6	708	12.2	2.77	9.4	35.4	4.39	1.5		0.6	18.80	613.6	11.3	8.15	0.72	1.07	12.38	10.6	-
			542.8	12.1	2.74	9.4	39.6	4.42	1.7	708	12.4	2.80	9.6	35.6	4.43	1.5		0.3	4.55	472	12.1	8.67	0.72	1.10	13.16	11.0	-
4.4	0.3	7.03	542.8	12.1	2.74	9.4	39.6	4.42	1.7	708	12.4	2.80	9.6	35.6	4.43	1.5	4.4	0.4	11.02	472	12.1	8.67	0.72	1.06	13.13	11.4	-
			542.8	12.5	2.80	9.6	40.1	4.44	1.7	708	12.7	2.85	9.8	36.0	4.46	1.5		0.6	18.24	472	12.2	8.72	0.72	1.06	13.22	11.5	-
	0.5	17.48	542.8	13.5	2.85	10.6	41.7	4.73	1.7	708	13.6	2.88	10.7	37.0	4.72	1.6		0.6	18.24	613.6	12.1	9.01	0.74	1.18	13.27	10.3	-
			542.8	13.6	2.84	10.8	41.9	4.79	1.9	708	14.0	2.91	11.1	37.5	4.80	1.7		0.3	4.41	472	12.9	9.48	0.73	1.25	14.15	10.3	-
	0.7	22.80	542.8	13.9	2.93	11.0	42.3	4.74	1.9	708	14.2	2.94	11.3	37.7	4.83	2.0		0.4	10.68	613.6	12.9	9.94	0.77	1.38	14.32	9.4	-
			542.8	14.2	2.94	11.3	37.7	4.83	2.0	708	14.2	2.94	11.3	37.7	4.83	2.0		0.6	17.67	472	13.1	9.54	0.73	1.20	14.26	10.9	-
10.0	0.3	6.83	542.8	14.9	2.87	12.0	43.8	5.18	1.8	708	15.1	2.89	12.2	38.8	5.23	1.7	10.0	0.3	4.41	472	12.9	9.84	0.76	1.40	14.34	9.2	-
			542.8	15.2	2.88	12.4	44.4	5.29	2.0	708	15.5	2.92	12.5	39.2	5.29	1.7		0.4	10.68	472	12.9	9.50	0.73	1.21	14.13	10.7	-
	0.5	16.94	542.8	15.2	2.88	12.4	44.4	5.29	2.0	708	15.5	2.92	12.5	39.2	5.29	1.7		0.6	17.67	613.6	12.9	9.94	0.77	1.38	14.32	9.4	-
			542.8	15.6	2.93	12.6	44.9	5.31	2.0	708	15.9	2.97	12.9	39.7	5.36	1.7		0.3	4.41	472	13.1	9.54	0.73	1.20	14.26	10.9	-
	0.7	21.39	542.8	15.9	2.97	12.9	39.7	5.36	1.7	708	15.9	2.97	12.9	39.7	5.36	1.7		0.4	10.68	613.6	13.1	9.94	0.76	1.31	14.38	10.0	-
			542.8	16.1	2.95	13.1	45.7	5.45	1.9	708	16.5	3.00	13.5	40.5	5.51	1.8		0.6	17.67	472	11.8	9.05	0.77	1.45	13.27	8.1	0.5
15.6	0.3	6.41	542.8	16.1	2.95	13.1	45.7	5.45	1.9	708	16.5	3.00	13.5	40.5	5.51	1.8	15.6	0.3	4.27	472	11.8	9.05	0.77	1.45	13.27	8.1	0.5
			542.8	16.7	3.02	13.6	46.5	5.52	2.0	708	17.0	2.95	14.0	41.0	5.75	1.9		0.6	17.67	613.6	12.1	9.61	0.79	1.59	13.68	7.6	0.6
	0.5	16.40	542.8	16.7	3.02	13.6	46.5	5.52	2.0	708	17.0	2.95	14.0	41.0	5.75	1.9		0.4	10.34	472	11.9	9.09	0.77	1.40	13.26	8.5	0.6
			542.8	17.2	3.08	14.1	47.4	5.58	2.2	708	17.6	3.01	14.6	41.7	5.84	1.9		0.6	17.11	613.6	12.2	9.66	0.79	1.55	13.70	7.9	0.6
	0.7	21.39	542.8	17.2	3.08	14.1	47.4	5.58	2.2	708	17.6	3.01	14.6	41.7	5.84	1.9		0.6	17.11	472	12.0	9.15	0.76	1.39	13.37	8.6	0.6
			542.8	17.6	3.01	14.6	41.7	5.84	1.9	708	17.6	3.01	14.6	41.7	5.84	1.9		0.6	17.11	613.6	12.2	9.71	0.79	1.49	13.70	8.2	0.6
21.1	0.3	6.21	542.8	17.6	3.01	14.6	41.7	5.84	1.9	708	17.6	3.01	14.6	41.7	5.84	1.9	21.1	0.3	4.14	472	11.4	8.89	0.78	1.68	13.08	6.8	0.8
			542.8	18.0	3.16	14.8	42.1	5.68	1.8	708	18.0	3.16	14.8	42.1	5.68	1.8		0.4	10.00	613.6	10.8	8.70	0.81	1.84	12.63	5.9	0.8
	0.5	15.86	542.8	18.0	3.16	14.8	42.1	5.68	1.8	708	18.0	3.16	14.8	42.1	5.68	1.8		0.6	16.55	472	11.5	8.95	0.78	1.62	13.07	7.1	0.9
			542.8	18.6	3.17	15.4	42.9	5.85	1.9	708	19.0	3.35	15.6	50.1	5.66	2.2		0.6	16.55	613.6	12.0	9.66	0.80	1.74	13.77	6.9	0.9
	0.7	20.68	542.8	18.6	3.17	15.4	42.9	5.85	1.9	708	19.0	3.35	15.6	50.1	5.66	2.2		0.6	16.55	472	10.6	7.62	0.72	1.62	12.23	6.5	0.9
			542.8	19.1	3.25	15.8	43.4	5.87	2.1	708	19.3	3.29	16.0	43.7	5.86	2.0		0.6	16.55	613.6	12.0	9.76	0.81	1.69	13.72	7.1	1.0
26.7	0.3	6.00	542.8	18.6	3.17	15.4	42.9	5.85	1.9	708	19.0	3.35	15.6	50.1	5.66	2.2	26.7	0.3	3.93	472	11.1	9.00	0.81	1.95	13.04	5.7	1.2
			542.8	19.1	3.25	15.8	43.4	5.87	2.1	708	19.3	3.29	16.0	43.7	5.86	2.0		0.4	9.66	613.6	11.4	9.62	0.85	2.08	13.47	5.5	1.2
	0.5	15.32	542.8	19.1	3.25	15.8	43.4	5.87	2.1	708	19.3	3.29	16.0	43.7	5.86	2.0		0.6	15.98	472	11.2	9.07	0.81	1.88	13.04	5.9	1.2
			542.8	19.3	3.29	16.0	43.7	5.86	2.0	708	19.3	3.29	16.0	43.7	5.86	2.0		0.6	15.98	613.6	11.5	9.62	0.84	1.98	13.48	5.8	1.2
	0.7	19.98	542.8	19.3	3.29	16.0	43.7	5.86	2.0	708	19.3	3.29	16.0	43.7	5.86	2.0		0.6	15.98	472	11.3	9.15	0.81	1.85	13.12	6.1	1.3
			542.8	19.9	3.32	16.9	44.8	6.07	2.1	708	20.1	3.48	16.6	51.7	5.76	2.5		0.6	15.98	613.6	11.6	9.72	0.84	1.93	13.48	6.0	1.3
32.2	0.3	5.79	542.8	19.9	3.32	16.9	44.8	6.07	2.1	708	20.1	3.48	16.6	51.7	5.76	2.5	32.2	0.3	3.79	472	10.0	8.61	0.86	2.25	12.29	4.5	1.6
			542.8	20.1	3.48	16.6	51.7	5.76	2.5	708	20.6	3.42	17.2	45.2	6.01	2.3		0.4	9.31	613.6	10.1	9.06	0.90	2.39	12.50	4.2	1.6
	0.5	14.77	542.8	20.1	3.48	16.6	51.7	5.76	2.5	708	20.6	3.42	17.2	45.2	6.01	2.3		0.6	15.41	472	10.1	8.70	0.86	2.16	12.28	4.7	1.6
			542.8	20.2	3.33	16.9	44.8	6.07	2.1	708	20.6	3.42	17.2	45.2	6.01	2.3		0.6	15.41	613.6	10.2	9.06	0.89	2.26	12.47	4.5	1.6
	0.7	19.27	542.8	20.2	3.33	16.9	44.8	6.07	2.1	708	20.6	3.42	17.2	45.2	6.01	2.3		0.6	15.41	472	10.2	8.79	0.86	2.12	12.34	4.8	1.7
			542.8	20.6	3.42	17.2	45.2	6.01	2.3	708	20.6	3.42	17.2	45.2	6.01	2.3		0.6	15.41	613.6	10.3	9.16	0.89	2.19	12.51	4.7	1.7
37.8	0.3	5.52	Operation not recommended										37.8	0.3	3.65	472	9.8	8.48	0.86	2.61	12.44	3.8	2.0				
	0.5	14.24												0.4	8.98	472	9.9	8.58	0.87	2.50	12.42	4.0	2.1				
	0.7	18.57												0.6	14.86	472	10.0	8.68	0.87	2.44	12.47	4.1	2.2				
43.3	0.3	5.31	Operation not recommended										43.3	0.3	3.52	472	8.7	7.83	0.90	3.01	11.71	2.9	2.4				
	0.5	13.70												0.4	8.64	472	8.										

Performance Data cont.

NVK012 - 50% Part Load

EWT °C	Flow L/s	WPD kPa	HEATING - EAT 21.1°C							EWT °C	Flow L/s	WPD kPa	COOLING - EAT 26.7/19.4°C								
			Airflow L/s	HC kW	Power kW	HE kW	LAT °C	COP	HWC kW				Airflow L/s	TC kW	SC kW	S/T Ratio	Power kW	HR kW	EER	HWC kW	
-6.7	0.2	3.87	Operation not recommended							-6.7	0.2	3.23	Operation not recommended								
	0.3	6.66	Operation not recommended								0.3	5.61	Operation not recommended								
	0.4	9.44	306.8	5.2	1.55	3.6	35.0	3.33	0.7		0.4	7.99	Operation not recommended								
-1.1	0.2	3.76	306.8	5.9	1.54	4.3	37.0	3.81	0.8	-1.1	0.2	3.13	236	8.2	4.49	0.55	0.53	8.69	15.5	-	
			424.8	6.0	1.57	4.4	32.7	3.80	0.7				354	8.0	4.45	0.56	0.58	8.57	13.7	-	
	0.3	6.46	306.8	6.2	1.58	4.6	37.8	3.90	0.9		0.3	5.44	236	8.2	4.48	0.55	0.51	8.67	16.0	-	
			424.8	6.3	1.60	4.7	33.4	3.94	0.8				354	7.9	4.62	0.58	0.62	8.51	12.8	-	
	0.4	9.16	306.8	6.3	1.60	4.7	38.1	3.94	0.9		0.4	7.75	236	8.3	5.04	0.61	0.51	8.81	16.4	-	
			424.8	6.4	1.61	4.8	33.6	3.96	0.8				354	8.0	4.57	0.57	0.58	8.60	13.9	-	
4.4	0.2	3.65	306.8	7.0	1.58	5.5	40.1	4.45	0.9	4.4	0.2	3.04	236	8.5	5.11	0.60	0.61	9.12	14.0	-	
			424.8	7.2	1.59	5.6	35.1	4.49	0.8				354	8.5	5.22	0.62	0.68	9.16	12.5	-	
	0.3	6.27	306.8	7.4	1.62	5.8	41.1	4.57	1.0		0.3	5.28	236	8.5	5.11	0.60	0.59	9.10	14.5	-	
			424.8	7.5	1.63	5.9	35.8	4.64	0.8				354	8.4	5.33	0.63	0.69	9.13	12.3	-	
	0.4	8.89	306.8	7.5	1.64	5.9	41.4	4.59	1.0		0.4	7.52	236	8.6	5.18	0.60	0.58	9.21	14.8	-	
			424.8	7.7	1.64	6.0	36.1	4.68	0.8				354	8.5	5.31	0.62	0.65	9.19	13.1	-	
10.0	0.2	3.53	306.8	7.8	1.66	6.2	42.3	4.71	1.0	10.0	0.2	2.95	236	9.1	5.84	0.64	0.71	9.81	12.8	-	
			424.8	8.0	1.66	6.3	36.7	4.81	0.8				354	9.1	6.06	0.66	0.80	9.93	11.4	-	
	0.3	6.08	306.8	8.2	1.70	6.5	43.3	4.84	1.0		0.3	5.12	236	9.1	5.85	0.64	0.69	9.80	13.3	-	
			424.8	8.4	1.70	6.7	37.5	4.94	0.9				354	9.1	6.13	0.67	0.78	9.91	11.7	-	
	0.4	8.62	306.8	8.3	1.72	6.6	43.6	4.85	1.1		0.4	7.29	236	9.2	5.88	0.64	0.68	9.89	13.5	-	
			424.8	8.5	1.71	6.8	37.8	4.99	1.0				354	9.2	6.13	0.66	0.75	9.97	12.4	-	
15.6	0.2	3.42	306.8	8.9	1.72	7.2	45.2	5.19	1.1	15.6	0.2	2.85	236	8.3	5.57	0.67	0.82	9.12	10.2	0.3	
			424.8	9.1	1.70	7.4	38.9	5.36	0.9				354	8.5	5.91	0.70	0.90	9.39	9.5	0.4	
	0.3	5.88	306.8	9.3	1.75	7.6	46.3	5.32	1.1		0.3	4.95	236	8.3	5.59	0.67	0.79	9.12	10.6	0.4	
			424.8	9.6	1.74	7.8	39.8	5.50	1.0				354	8.5	5.94	0.70	0.87	9.41	9.8	0.4	
	0.4	8.34	306.8	9.5	1.78	7.7	46.8	5.34	1.2		0.4	7.06	236	8.4	5.63	0.67	0.78	9.20	10.8	0.4	
			424.8	9.7	1.75	8.0	40.1	5.55	1.0				354	8.6	5.97	0.70	0.84	9.42	10.3	0.4	
21.1	0.2	3.31	306.8	10.0	1.80	8.2	48.1	5.56	1.2	21.1	0.2	2.76	236	7.9	5.56	0.70	1.01	8.93	7.8	0.5	
			424.8	9.9	1.79	8.1	40.5	5.55	1.0				354	8.1	5.93	0.74	1.18	9.24	6.8	0.5	
	0.3	5.69	306.8	10.4	1.83	8.6	49.2	5.69	1.3		0.3	4.79	236	8.0	5.59	0.70	0.98	8.93	8.2	0.6	
			424.8	10.7	1.81	8.9	42.1	5.94	1.1				354	8.4	6.03	0.72	1.05	9.40	8.0	0.6	
	0.4	8.07	306.8	10.4	1.84	8.6	49.3	5.67	1.3		0.4	6.83	236	6.9	4.07	0.62	1.01	7.93	6.8	0.5	
			424.8	10.9	1.82	9.1	42.4	5.99	1.1				354	8.4	6.10	0.73	1.02	9.37	8.2	0.6	
26.7	0.2	3.20	306.8	10.7	1.83	8.8	49.9	5.83	1.2	26.7	0.2	2.66	236	7.8	5.66	0.73	1.19	8.98	6.6	0.7	
			424.8	11.0	1.84	9.1	42.5	5.96	1.0				354	8.0	6.05	0.76	1.27	9.27	6.3	0.7	
	0.3	5.49	306.8	11.1	1.87	9.3	51.2	5.95	1.3		0.3	4.63	236	7.8	5.70	0.73	1.14	8.98	6.9	0.8	
			424.8	11.5	1.88	9.6	43.5	6.11	1.1				354	8.1	6.05	0.75	1.21	9.29	6.7	0.8	
	0.4	7.79	306.8	11.3	1.91	9.4	51.7	5.93	1.4		0.4	6.59	236	7.9	5.75	0.73	1.12	9.04	7.0	0.8	
			424.8	11.7	1.90	9.8	43.9	6.15	1.2				354	8.1	6.11	0.75	1.17	9.29	6.9	0.9	
32.2	0.2	3.08	306.8	11.3	1.88	9.5	51.8	6.04	1.3	32.2	0.2	2.57	236	7.1	5.31	0.75	1.41	8.51	5.0	1.0	
			424.8	11.7	1.89	9.8	44.0	6.20	1.1				354	7.2	5.59	0.78	1.49	8.65	4.8	1.0	
	0.3	5.30	306.8	11.8	1.92	9.9	53.1	6.17	1.4		0.3	4.46	236	7.2	5.36	0.75	1.35	8.51	5.3	1.0	
			424.8	12.3	1.93	10.3	45.0	6.36	1.2				354	7.2	5.59	0.77	1.41	8.64	5.1	1.0	
	0.4	7.51	306.8	12.0	1.97	10.1	53.6	6.11	1.5		0.4	6.36	236	7.2	5.42	0.75	1.33	8.55	5.4	1.1	
			424.8	12.5	1.95	10.5	45.5	6.40	1.3				354	7.3	5.64	0.77	1.37	8.67	5.3	1.1	
37.8	0.2	2.97	Operation not recommended							37.8	0.2	2.48	236	6.9	5.37	0.77	1.70	8.65	4.1	1.3	
	0.3	5.11									354	7.0	5.62	0.80	1.75	8.76	4.0	1.3			
	0.4	7.24									236	7.0	5.43	0.78	1.63	8.64	4.3	1.3			
43.3	0.2	2.86								43.3	4.30	354	7.1	5.66	0.80	1.67	8.75	4.2	1.3		
												0.3	4.14	236	7.1	5.49	0.78	1.60	8.67	4.4	1.4
														354	7.1	5.72	0.80	1.63	8.78	4.4	1.4
	0.3	4.91								43.3	5.90	236	6.3	5.04	0.80	1.97	8.25	3.2	1.5		
												354	6.3	5.25	0.83	1.99	8.34	3.2	1.5		
												236	6.3	5.11	0.81	1.89	8.24	3.4	1.6		
48.9	0.2	2.75								48.9	2.29	354	6.4	5.33	0.83	1.91	8.32	3.4	1.6		
												0.3	3.98	236	6.4	5.18	0.81	1.84	8.25	3.5	1.7
														354	6.5	5.39	0.83	1.86	8.34	3.5	1.7
	0.3	4.72								48.9	5.67	236	5.8	4.69	0.81	2.39	8.18	2.4	1.9		
												354	5.7	4.70	0.83	2.30	8.00	2.5	1.9		
												236	5.8	4.76	0.81	2.29	8.14	2.6	1.9		
0.4	6.70	48.9	5.67	354	5.7	4.84	0.85	2.30	8.03	2.5	1.9										
				236	6.0	4.95	0.83	2.21	8.16	2.7	2.0										
												354	5.8	4.89	0.84	2.23	8.06	2.6	2.0		

Performance Data cont.

NVK012 - 100% Full Load

EWT °C	Flow L/s	WPD kPa	HEATING - EAT 21.1°C							EWT °C	Flow L/s	WPD kPa	COOLING - EAT 26.7/19.4°C							
			Airflow L/s	HC kW	Power kW	HE kW	LAT °C	COP	HWC kW				Airflow L/s	TC kW	SC kW	S/T Ratio	Power kW	HR kW	EER	HWC kW
-6.7	0.4	9.68	Operation not recommended							-6.7	0.3	7.26	Operation not recommended							
	0.6	19.67	Operation not recommended								0.5	13.76	Operation not recommended							
	0.9	33.00	708	11.9	3.67	8.2	35.0	3.24	1.8		0.7	20.25	Operation not recommended							
-1.1	0.4	9.40	708	13.2	3.86	9.3	36.5	3.41	1.9	-1.1	0.3	7.05	472	15.4	10.63	0.69	1.21	16.62	12.7	-
		849.6	12.2	3.72	8.5	33.0	3.28	1.6	660.8			15.1	10.64	0.70	1.35	16.45	11.2	-		
	0.6	19.10	708	13.3	3.90	9.4	36.6	3.40	2.0		0.5	13.36	472	15.4	10.61	0.69	1.17	16.57	13.2	-
		849.6	13.5	3.97	9.6	34.3	3.41	1.8	660.8			14.9	10.92	0.73	1.41	16.32	10.6	-		
	0.9	32.04	708	13.5	4.11	9.4	36.9	3.27	2.0		0.7	19.66	472	15.4	10.70	0.69	1.17	16.62	13.2	-
		849.6	14.0	4.07	9.9	34.7	3.43	1.9	660.8			15.2	10.81	0.71	1.32	16.47	11.5	-		
4.4	0.4	9.12	708	14.6	3.94	10.6	38.2	3.70	2.1	4.4	0.3	6.84	472	15.8	10.89	0.69	1.40	17.17	11.3	-
		849.6	14.8	4.00	10.8	35.5	3.70	1.8	660.8			15.7	11.16	0.71	1.56	17.29	10.1	-		
	0.6	18.53	708	14.7	3.95	10.8	38.3	3.72	2.1		0.5	12.96	472	15.8	10.89	0.69	1.35	17.13	11.7	-
		849.6	15.1	4.04	11.0	35.8	3.73	1.9	660.8			15.6	11.36	0.73	1.58	17.22	9.9	-		
	0.9	31.08	708	15.1	4.04	11.1	38.8	3.74	2.2		0.7	19.07	472	15.9	10.95	0.69	1.35	17.25	11.8	-
		849.6	15.4	4.11	11.3	36.1	3.75	1.9	660.8			15.8	11.31	0.71	1.49	17.32	10.6	-		
10.0	0.4	8.84	708	17.0	4.04	13.0	41.0	4.20	2.2	10.0	0.3	6.63	472	16.6	11.40	0.69	1.64	18.26	10.2	-
		849.6	17.2	4.09	13.1	37.9	4.20	2.1	660.8			16.7	11.84	0.71	1.83	18.51	9.1	-		
	0.6	17.95	708	17.2	4.03	13.1	41.2	4.26	2.4		0.5	12.56	472	16.7	11.43	0.69	1.58	18.24	10.6	-
		849.6	17.6	4.13	13.5	38.3	4.27	2.1	660.8			16.7	11.96	0.72	1.80	18.48	9.3	-		
	0.9	30.12	708	17.6	4.16	13.4	41.7	4.22	2.5		0.7	18.48	472	16.8	11.49	0.68	1.57	18.40	10.7	-
		849.6	17.9	4.17	13.8	38.6	4.30	2.5	660.8			16.9	11.96	0.71	1.71	18.56	9.9	-		
15.6	0.4	8.56	708	18.5	3.99	14.5	42.8	4.64	2.2	15.6	0.3	6.42	472	15.0	10.71	0.71	1.88	16.90	8.0	0.8
		849.6	18.8	4.03	14.8	39.5	4.67	2.1	660.8			15.4	11.36	0.74	2.06	17.42	7.5	0.8		
	0.6	17.38	708	19.0	4.01	15.0	43.3	4.73	2.5		0.5	12.16	472	15.1	10.75	0.71	1.81	16.88	8.3	0.8
		849.6	19.2	4.07	15.2	39.9	4.73	2.1	660.8			15.4	11.42	0.74	2.00	17.44	7.7	0.8		
	0.9	29.16	708	19.4	4.08	15.3	43.8	4.75	2.5		0.7	17.89	472	15.2	10.82	0.71	1.80	17.01	8.5	0.8
		849.6	19.8	4.13	15.7	40.4	4.79	2.2	660.8			15.5	11.48	0.74	1.93	17.44	8.1	0.9		
21.1	0.4	8.27	708	19.8	4.02	15.8	44.3	4.93	2.4	21.1	0.3	6.21	472	14.3	10.26	0.72	2.22	16.52	6.5	1.0
		849.6	20.0	3.94	16.1	40.6	5.08	2.2	660.8			14.0	10.08	0.72	2.52	16.47	5.5	1.1		
	0.6	16.81	708	20.9	4.00	16.9	45.6	5.23	2.5		0.5	11.76	472	14.4	10.32	0.72	2.13	16.51	6.7	1.1
		849.6	21.0	4.02	17.0	41.6	5.23	2.3	660.8			15.1	11.14	0.74	2.30	17.38	6.6	1.1		
	0.9	28.20	708	21.3	4.61	16.7	46.0	4.62	2.8		0.7	17.31	472	12.9	8.76	0.68	2.17	15.07	5.9	1.1
		849.6	21.8	4.10	17.7	42.3	5.31	2.4	660.8			15.1	11.25	0.75	2.23	17.32	6.8	1.2		
26.7	0.4	7.99	708	22.0	4.01	18.0	46.8	5.48	2.6	26.7	0.3	5.99	472	13.9	10.31	0.74	2.56	16.48	5.4	1.6
		849.6	22.4	4.01	18.4	42.9	5.57	2.3	660.8			14.3	11.03	0.77	2.73	17.02	5.2	1.6		
	0.6	16.24	708	23.0	4.08	18.9	48.0	5.63	2.8		0.5	11.36	472	14.0	10.39	0.74	2.46	16.47	5.7	1.7
		849.6	23.1	4.03	19.1	43.7	5.74	2.3	660.8			14.4	11.03	0.76	2.60	17.04	5.5	1.7		
	0.9	27.24	708	23.3	4.13	19.2	48.4	5.65	2.8		0.7	16.72	472	14.1	10.49	0.74	2.42	16.57	5.8	1.7
		849.6	23.8	4.16	19.6	44.3	5.72	2.6	660.8			14.5	11.14	0.77	2.53	17.03	5.7	1.7		
32.2	0.4	7.71	708	23.7	4.04	19.7	48.9	5.88	2.8	32.2	0.3	5.78	472	12.5	9.79	0.78	2.94	15.46	4.3	2.0
		849.6	24.1	4.03	20.1	44.6	5.99	2.5	660.8			12.6	10.30	0.82	3.12	15.73	4.0	1.9		
	0.6	15.66	708	25.0	4.13	20.9	50.4	6.05	2.8		0.5	10.95	472	12.6	9.89	0.78	2.83	15.44	4.5	2.1
		849.6	25.3	4.03	21.3	45.8	6.28	2.6	660.8			12.7	10.30	0.81	2.95	15.68	4.3	2.1		
	0.9	26.27	708	25.1	4.35	20.8	50.5	5.77	3.0		0.7	16.12	472	12.7	9.99	0.78	2.77	15.51	4.6	2.1
		849.6	25.8	4.20	21.6	46.3	6.14	2.8	660.8			12.9	10.40	0.81	2.86	15.73	4.5	2.2		
37.8	0.4	7.43	Operation not recommended							37.8	0.3	5.57	472	12.4	9.65	0.78	3.45	15.87	3.6	2.6
	0.6	15.09	Operation not recommended								0.5	10.56	660.8	12.5	10.10	0.81	3.55	16.09	3.5	2.6
	0.9	25.32	Operation not recommended								0.7	15.54	472	12.5	9.77	0.78	3.30	15.84	3.8	2.7
43.3	0.4	7.15	Operation not recommended							43.3	0.3	5.36	472	11.4	9.28	0.82	3.93	15.30	2.9	3.1
	0.6	14.52	Operation not recommended								0.5	10.16	660.8	11.5	9.67	0.84	3.97	15.46	2.9	3.1
	0.9	24.36	Operation not recommended								0.7	14.95	472	11.6	9.54	0.82	3.67	15.28	3.2	3.4
48.9	0.4	6.87	Operation not recommended							48.9	0.3	5.15	472	10.6	8.52	0.80	4.57	15.15	2.3	3.7
	0.6	13.95	Operation not recommended								0.5	9.76	660.8	10.4	8.65	0.83	4.45	14.88	2.3	3.9
	0.9	23.41	Operation not recommended								0.7	14.36	472	10.7	8.66	0.81	4.38	15.08	2.4	3.9
			Operation not recommended										660.8	10.5	8.81	0.84	4.39	14.88	2.4	4.0
			Operation not recommended										472	10.7	8.83	0.82	4.26	15.00	2.5	4.1
			Operation not recommended										660.8	10.7	8.90	0.83	4.26	14.93	2.5	4.1

Performance Data cont.

NVK015 - 50% Part Load

EWT °C	Flow L/s	WPD kPa	HEATING - EAT 21.1°C							EWT °C	Flow L/s	WPD kPa	COOLING - EAT 26.7/19.4°C							
			Airflow L/s	HC kW	Power kW	HE kW	LAT °C	COP	HWC kW				Airflow L/s	TC kW	SC kW	S/T Ratio	Power kW	HR kW	EER	HWC kW
-6.7	0.3	4.36	Operation not recommended							-6.7	0.3	2.99	Operation not recommended							
	0.4	8.07	Operation not recommended								0.4	8.39	Operation not recommended							
	0.5	13.39	401.2	6.6	2.18	4.4	34.7	3.02	1.0		0.5	12.42	Operation not recommended							
-1.1	0.3	4.23	401.2	7.6	2.15	5.5	36.9	3.55	1.1	-1.1	0.3	2.90	330.4	10.8	6.28	0.58	0.74	11.53	14.5	-
			519.2	7.8	2.18	5.6	33.5	3.56	1.0				448.4	10.4	6.27	0.60	0.84	11.28	12.5	-
	0.4	7.83	401.2	7.7	2.17	5.5	37.0	3.55	1.2		0.4	8.15	330.4	10.8	6.27	0.58	0.72	11.50	15.0	-
			519.2	7.8	2.21	5.6	33.6	3.56	1.0				448.4	10.4	6.45	0.62	0.87	11.31	12.0	-
	0.5	13.00	401.2	7.8	2.29	5.5	37.2	3.41	1.2		0.5	12.06	330.4	11.0	6.63	0.60	0.71	11.70	15.5	-
			519.2	8.1	2.26	5.8	34.0	3.57	1.1				448.4	10.6	6.39	0.60	0.81	11.42	13.0	-
4.4	0.3	4.10	401.2	9.1	2.22	6.8	39.8	4.08	1.3	4.4	0.3	2.81	330.4	11.0	6.91	0.63	0.86	11.91	12.8	-
			519.2	9.2	2.25	6.9	35.8	4.08	1.1				448.4	11.0	7.08	0.65	0.97	11.94	11.3	-
	0.4	7.60	401.2	9.2	2.23	6.9	40.0	4.10	1.3		0.4	7.90	330.4	11.1	6.91	0.63	0.83	11.89	13.2	-
			519.2	9.4	2.28	7.1	36.1	4.11	1.1				448.4	11.0	7.21	0.66	0.98	11.93	11.2	-
	0.5	12.61	401.2	9.4	2.28	7.1	40.5	4.12	1.4		0.5	11.70	330.4	11.2	7.07	0.63	0.83	12.02	13.5	-
			519.2	9.6	2.32	7.3	36.4	4.14	1.1				448.4	11.1	7.18	0.65	0.92	12.00	12.0	-
10.0	0.3	3.98	401.2	10.3	2.34	8.0	42.4	4.41	1.4	10.0	0.3	2.72	330.4	11.2	7.34	0.66	1.02	12.18	11.0	-
			519.2	10.4	2.36	8.0	37.7	4.40	1.2				448.4	11.2	7.62	0.68	1.14	12.34	9.8	-
	0.4	7.36	401.2	10.4	2.33	8.1	42.6	4.46	1.4		0.4	7.66	330.4	11.2	7.36	0.66	0.98	12.17	11.4	-
			519.2	10.7	2.39	8.3	38.2	4.47	1.2				448.4	11.2	7.70	0.69	1.12	12.32	10.0	-
	0.5	12.22	401.2	10.6	2.41	8.2	43.1	4.42	1.5		0.5	11.34	330.4	11.3	7.39	0.65	0.98	12.27	11.6	-
			519.2	10.9	2.41	8.5	38.5	4.51	1.4				448.4	11.3	7.70	0.68	1.06	12.38	10.6	-
15.6	0.3	3.85	401.2	11.5	2.33	9.2	44.9	4.94	1.5	15.6	0.3	2.64	330.4	11.0	7.71	0.70	1.22	12.24	9.1	0.4
			519.2	11.7	2.35	9.3	39.8	4.98	1.2				448.4	11.3	8.18	0.73	1.33	12.61	8.5	0.5
	0.4	7.13	401.2	11.8	2.34	9.4	45.4	5.03	1.6		0.4	7.41	330.4	11.1	7.74	0.70	1.17	12.23	9.4	0.5
			519.2	11.9	2.37	9.6	40.2	5.04	1.3				448.4	11.3	8.22	0.73	1.29	12.63	8.7	0.5
	0.5	11.83	401.2	12.0	2.38	9.7	46.0	5.06	1.6		0.5	10.98	330.4	11.2	7.79	0.70	1.16	12.33	9.6	0.5
			519.2	12.3	2.41	9.9	40.7	5.10	1.4				448.4	11.4	8.26	0.73	1.25	12.63	9.1	0.5
21.1	0.3	3.72	401.2	12.5	2.33	10.2	46.9	5.36	1.6	21.1	0.3	2.55	330.4	10.6	7.72	0.73	1.39	12.03	7.7	0.6
			519.2	13.1	2.40	10.7	42.1	5.47	1.3				448.4	11.4	8.31	0.73	1.53	12.94	7.4	0.7
	0.4	6.89	401.2	12.7	2.39	10.3	47.3	5.31	1.7		0.4	7.17	330.4	10.7	7.77	0.73	1.33	12.03	8.0	0.7
			519.2	13.3	2.33	10.9	42.3	5.68	1.4				448.4	11.2	8.39	0.75	1.44	12.66	7.8	0.7
	0.5	11.45	401.2	13.1	2.44	10.7	48.2	5.38	1.8		0.5	10.62	330.4	10.6	6.76	0.64	1.37	11.93	7.7	0.7
			519.2	13.7	2.38	11.4	43.0	5.78	1.5				448.4	11.2	8.47	0.75	1.40	12.62	8.0	0.7
26.7	0.3	3.60	401.2	13.7	2.36	11.4	49.4	5.81	1.7	26.7	0.3	2.46	330.4	10.4	7.89	0.76	1.65	12.06	6.3	0.9
			519.2	14.0	2.36	11.6	43.4	5.91	1.4				448.4	10.7	8.43	0.79	1.76	12.45	6.1	0.9
	0.4	6.66	401.2	14.3	2.40	11.9	50.7	5.97	1.8		0.4	6.93	330.4	10.5	7.95	0.76	1.59	12.06	6.6	1.0
			519.2	14.4	2.39	12.0	44.1	6.03	1.5				448.4	10.8	8.43	0.78	1.68	12.47	6.4	1.0
	0.5	11.06	401.2	14.6	2.43	12.1	51.2	5.99	1.9		0.5	10.26	330.4	10.6	8.02	0.76	1.56	12.14	6.8	1.0
			519.2	14.9	2.45	12.4	44.8	6.06	1.6				448.4	10.8	8.52	0.79	1.63	12.47	6.7	1.2
32.2	0.3	3.47	401.2	14.8	2.41	12.4	51.6	6.12	1.8	32.2	0.3	2.38	330.4	10.1	8.11	0.80	1.97	12.12	5.1	1.3
			519.2	15.0	2.38	12.6	45.0	6.31	1.5				448.4	10.2	8.53	0.83	2.09	12.31	4.9	1.3
	0.4	6.42	401.2	15.4	2.48	12.9	52.9	6.20	1.9		0.4	6.68	330.4	10.2	8.19	0.80	1.89	12.12	5.4	1.3
			519.2	15.6	2.42	13.1	45.9	6.43	1.6				448.4	10.3	8.53	0.83	1.97	12.30	5.2	1.3
	0.5	10.66	401.2	15.6	2.51	13.1	53.4	6.22	2.1		0.5	9.89	330.4	10.3	8.27	0.80	1.86	12.19	5.6	1.4
			519.2	16.0	2.47	13.6	46.7	6.48	1.7				448.4	10.4	8.62	0.83	1.92	12.35	5.4	1.4
37.8	0.3	3.34	Operation not recommended							37.8	0.3	2.29	330.4	9.2	7.45	0.81	2.30	11.49	4.0	1.6
	0.4	6.19	Operation not recommended								0.4	6.44	330.4	9.3	7.54	0.81	2.21	11.47	4.2	1.6
	0.5	10.28	Operation not recommended								0.5	9.53	330.4	9.4	7.63	0.82	2.16	11.52	4.3	1.7
43.3	0.3	3.22	Operation not recommended							43.3	0.3	2.20	330.4	7.8	6.55	0.83	2.50	10.35	3.1	1.8
			448.4	7.9	6.82	0.86	2.53	10.45	3.1				1.8							
	0.4	5.96	Operation not recommended								0.4	6.19	330.4	7.9	6.64	0.84	2.40	10.33	3.3	2.0
			448.4	8.0	6.92	0.86	2.42	10.43	3.3				2.0							
	0.5	9.89	Operation not recommended								0.5	9.17	330.4	8.0	6.72	0.84	2.34	10.35	3.4	2.1
			448.4	8.1	7.00	0.87	2.36	10.45	3.4				2.1							
48.9	0.3	3.09	Operation not recommended							48.9	0.3	2.12	330.4	7.4	6.42	0.87	2.99	10.35	2.5	2.4
	0.4	5.72	Operation not recommended								0.4	5.95	330.4	7.4	6.53	0.88	2.87	10.30	2.6	2.5
	0.5	9.50	Operation not recommended								0.5	8.81	330.4	7.6	6.98	0.92	2.74	10.32	2.8	2.5
											448.4	7.4	6.71	0.91	2.79	10.21	2.7	2.5		

Performance Data cont.

NVK015 - 100% Full Load

EWT °C	Flow L/s	WPD kPa	HEATING - EAT 21.1°C							EWT °C	Flow L/s	WPD kPa	COOLING - EAT 26.7/19.4°C							
			Airflow L/s	HC kW	Power kW	HE kW	LAT °C	COP	HWC kW				Airflow L/s	TC kW	SC kW	S/T Ratio	Power kW	HR kW	EER	HWC kW
-6.7	0.5	13.79	Operation not recommended							-6.7	0.4	8.31	Operation not recommended							
	0.8	24.27									0.6	18.64								
	1.1	45.18	849.6	15.1	5.23	9.8	35.8	2.88	2.4		0.9	28.96								
	0.5	13.44	849.6	16.6	5.07	11.6	37.3	3.28	2.5	-1.1	0.4	8.07	708	20.4	13.59	0.67	1.86	22.24	11.0	-
		1038.4	17.0	5.16	11.8	34.6	3.29	2.3	849.6			20.0	13.61	0.68	2.08	22.05	9.6	-		
	0.8	23.57	849.6	16.8	5.12	11.7	37.5	3.28	2.5		0.6	18.09	708	20.4	13.57	0.67	1.80	22.17	11.3	-
		1038.4	17.1	5.21	11.9	34.8	3.28	2.3	849.6			19.7	13.97	0.71	2.18	21.90	9.1	-		
	0.5	13.10	849.6	19.0	5.16	13.8	39.6	3.68	2.6	-1.1	0.4	7.83	708	20.1	13.63	0.68	2.08	22.18	9.6	-
			1038.4	19.3	5.24	14.0	36.5	3.68	2.4				849.6	20.0	13.96	0.70	2.33	22.37	8.6	-
	0.8	22.86	849.6	19.2	5.18	14.0	39.8	3.70	2.7		0.6	17.55	708	20.1	13.63	0.68	2.01	22.13	10.0	-
			1038.4	19.6	5.29	14.3	36.8	3.71	2.5				849.6	19.9	14.22	0.71	2.35	22.29	8.5	-
	0.5	12.76	849.6	19.7	5.30	14.4	40.3	3.72	2.8	-1.1	0.4	7.59	708	20.3	13.71	0.68	2.01	22.28	10.1	-
			1038.4	20.1	5.38	14.7	37.1	3.73	2.5				849.6	20.2	14.16	0.70	2.23	22.39	9.1	-
	0.8	22.16	849.6	21.2	5.28	15.9	41.7	4.01	2.8		0.6	17.01	708	20.1	13.78	0.69	2.36	22.46	8.5	-
			1038.4	21.4	5.34	16.0	38.2	4.00	2.5				849.6	20.2	14.30	0.71	2.64	22.80	7.6	-
	0.5	12.41	849.6	21.4	5.27	16.1	42.0	4.06	2.9	-1.1	0.4	7.34	708	20.1	13.81	0.69	2.27	22.41	8.9	-
			1038.4	21.9	5.39	16.5	38.6	4.07	2.6				849.6	20.2	14.45	0.72	2.59	22.75	7.8	-
	0.8	21.45	849.6	21.9	5.44	16.4	42.4	4.02	3.0		0.6	26.44	708	20.3	13.88	0.68	2.26	22.60	9.0	-
			1038.4	22.3	5.45	16.9	38.9	4.10	2.7				849.6	20.4	14.45	0.71	2.46	22.83	8.3	-
	0.5	12.41	849.6	23.7	5.43	18.3	44.2	4.37	2.9	-1.1	0.4	7.34	708	18.7	13.24	0.71	2.68	21.36	7.0	0.9
			1038.4	24.1	5.47	18.6	40.3	4.40	2.6				849.6	19.1	14.06	0.74	2.93	22.05	6.5	0.9
	0.8	21.45	849.6	24.3	5.45	18.8	44.8	4.45	3.1		0.6	16.47	708	18.8	13.30	0.71	2.58	21.33	7.3	0.8
			1038.4	24.6	5.53	19.1	40.7	4.45	2.8				849.6	19.2	14.13	0.74	2.85	22.06	6.7	0.9
	0.5	12.07	849.6	24.8	5.55	19.2	45.3	4.47	3.2	-1.1	0.4	25.59	708	18.9	13.38	0.71	2.55	21.49	7.4	0.8
			1038.4	25.3	5.61	19.7	41.3	4.51	2.9				849.6	19.3	14.20	0.74	2.74	22.05	7.1	0.8
	0.8	20.74	849.6	25.9	5.68	20.2	46.4	4.56	3.1		0.6	15.93	708	17.6	12.93	0.73	3.03	20.67	5.8	1.4
			1038.4	26.4	5.63	20.7	42.1	4.68	2.8				849.6	18.4	13.83	0.75	3.41	21.80	5.4	1.4
	0.5	11.55	849.6	27.3	5.65	21.7	47.7	4.83	3.3	-1.1	0.4	7.10	708	17.7	13.01	0.73	2.91	20.64	6.1	1.3
			1038.4	27.4	5.68	21.8	43.0	4.83	2.9				849.6	18.6	14.04	0.75	3.14	21.75	5.9	1.3
	0.8	20.74	849.6	27.8	5.91	21.9	48.2	4.71	3.5		0.6	24.75	708	18.2	12.91	0.71	2.86	21.08	6.4	1.2
			1038.4	28.5	5.80	22.7	43.8	4.91	3.1				849.6	18.6	14.18	0.76	3.04	21.65	6.1	1.2
	0.5	11.55	849.6	28.6	5.74	22.9	49.0	4.98	3.4	-1.1	0.4	6.86	708	17.0	12.77	0.75	3.48	20.51	4.9	1.8
			1038.4	29.1	5.75	23.4	44.4	5.06	2.9				849.6	17.5	13.65	0.78	3.71	21.19	4.7	1.8
	0.8	20.04	849.6	29.9	5.84	24.1	50.3	5.12	3.6		0.6	15.39	708	17.1	12.87	0.75	3.34	20.48	5.1	1.7
			1038.4	30.2	5.78	24.4	45.2	5.21	3.1				849.6	17.7	13.65	0.77	3.53	21.19	5.0	1.7
	0.5	11.03	849.6	30.4	6.02	24.4	50.7	5.04	3.7	-1.1	0.4	23.91	708	17.3	12.98	0.75	3.29	20.60	5.3	1.6
			1038.4	31.0	5.96	25.0	45.8	5.19	3.3				849.6	17.7	13.79	0.78	3.43	21.17	5.2	1.6
	0.8	19.32	849.6	31.2	5.99	25.2	51.5	5.20	3.4		0.6	6.62	708	15.9	12.38	0.78	3.98	19.84	4.0	2.4
			1038.4	31.7	5.93	25.7	46.4	5.34	3.0				849.6	16.0	13.03	0.82	4.22	20.19	3.8	2.4
	0.5	10.34	849.6	32.8	6.08	26.7	53.1	5.40	3.7	-1.1	0.4	14.84	708	16.0	12.51	0.78	3.83	19.80	4.2	2.3
			1038.4	33.2	5.93	27.3	47.6	5.60	3.3				849.6	16.1	13.03	0.81	3.99	20.12	4.0	2.3
	0.8	17.92	849.6	33.0	6.40	26.6	53.3	5.15	3.9		0.6	23.06	708	16.1	12.63	0.78	3.75	19.89	4.3	2.1
			1038.4	33.8	6.18	27.7	48.1	5.48	3.5				849.6	16.3	13.16	0.81	3.87	20.17	4.2	2.2
37.8	0.5	10.69	Operation not recommended							37.8	0.4	6.38	708	15.0	12.13	0.81	4.50	19.52	3.3	3.0
	0.8	18.63									0.6	14.30	708	15.2	12.28	0.81	4.31	19.47	3.5	2.8
	1.1	34.67									0.9	22.23	849.6	15.3	12.79	0.84	4.42	19.73	3.5	2.9
43.3	0.5	10.34	Operation not recommended							43.3	0.4	6.14	708	15.3	12.42	0.81	4.22	19.53	3.6	2.7
	0.8	17.92									0.6	13.76	708	15.5	12.94	0.84	4.30	19.76	3.6	2.7
	1.1	33.36									0.9	21.38	849.6	15.5	12.94	0.84	4.30	19.76	3.6	2.7
48.9	0.5	9.65	Operation not recommended							48.9	0.4	5.89	708	13.6	11.42	0.84	5.06	18.65	2.7	3.8
	0.8	17.22									0.6	13.22	849.6	13.7	11.59	0.84	4.85	18.58	2.8	3.6
	1.1	32.05									0.9	20.54	708	13.9	11.73	0.85	4.73	18.60	2.9	3.4
	0.5	9.65	Operation not recommended							48.9	0.4	5.89	849.6	14.0	12.22	0.87	4.77	18.78	2.9	3.4
	0.8	17.22									0.6	13.22	708	12.6	11.31	0.90	5.75	18.31	2.2	4.7
	1.1	32.05									0.9	20.54	849.6	12.4	11.48	0.93	5.60	17.97	2.2	4.7
	0.5	9.65	Operation not recommended							48.9	0.4	5.89	708	12.7	11.72	0.92	5.36	18.10	2.4	4.2
	0.8	17.22									0.6	13.22	849.6	12.4	11.69	0.94	5.52	17.97	2.3	4.5
	1.1	32.05									0.9	20.54	708	12.7	11.72	0.92	5.36	18.10	2.4	4.2
	0.5	9.65	Operation not recommended							48.9	0.4	5.89	849.6	12.7	11.81	0.93	5.36	18.02	2.4	4.2
	0.8	17.22									0.6	13.22	708	12.7	11.72	0.92	5.36	18.10	2.4	4.2
	1.1	32.05									0.9	20.54	849.6	12.7	11.81	0.93	5.36	18.02	2.4	4.2

Wiring Schematics

Aurora Variable Speed

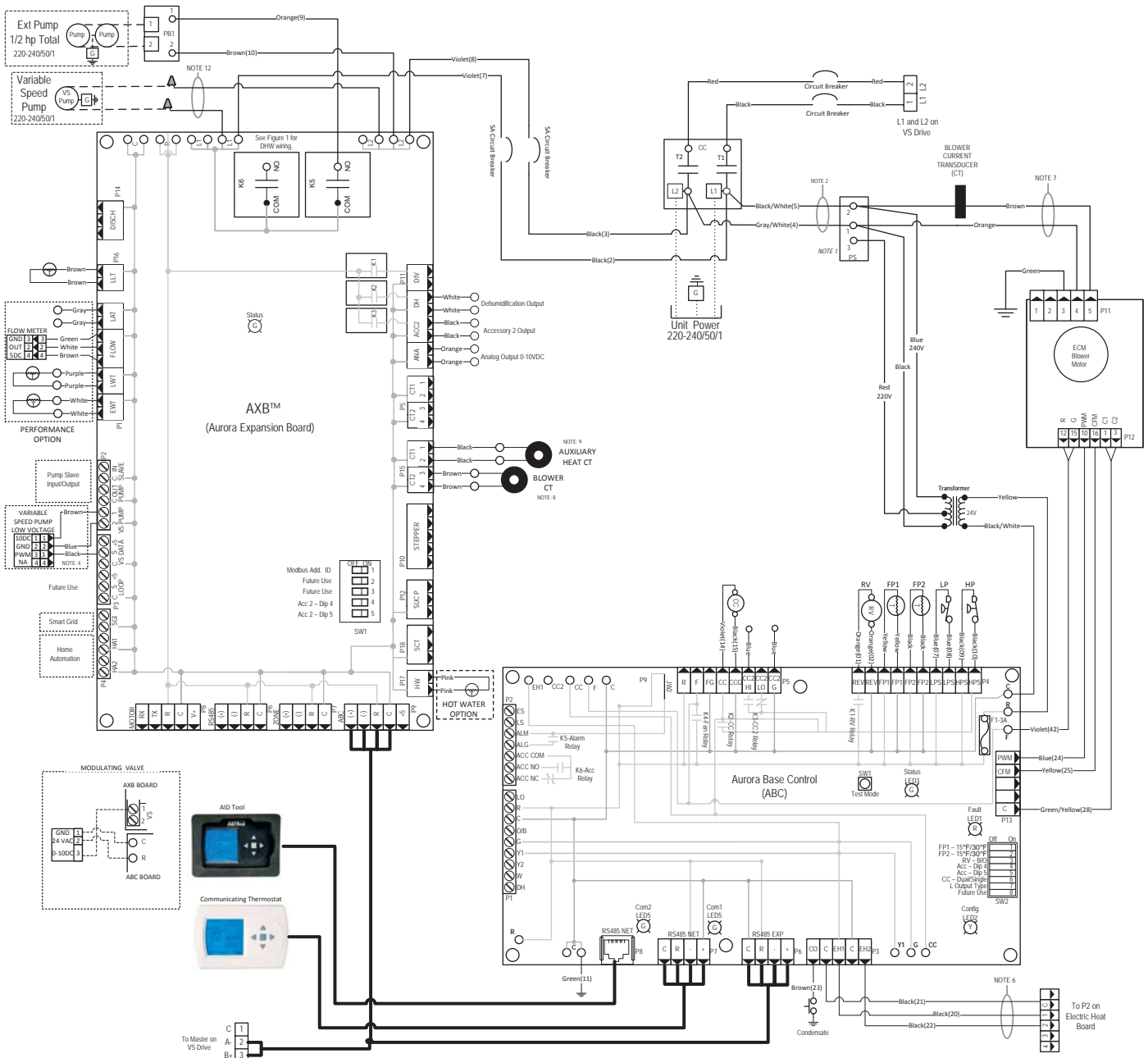

Wiring Schematics cont.

Aurora Variable Speed cont.

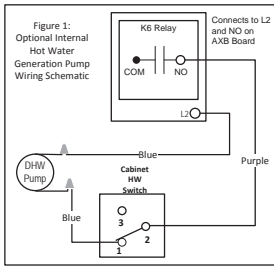
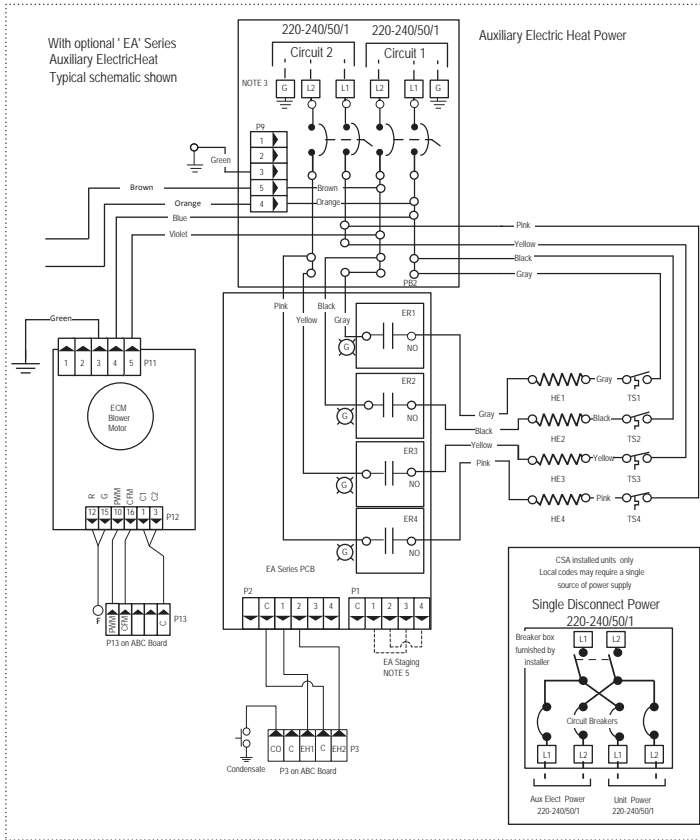

- Notes**
- 1 - Switch blue and red wires for 220V operation.
 - 2 - The blk/wh and gray/wh wires are removed when Aux Heat is installed
 - 3 - Use manufacturer's part number 19P592-01 (jumper bar assembly) when single source power is required.
 - 4 - Variable speed pump low voltage harness provided with Variable Speed Flow Center.
 - 5 - For additional Auxiliary Heat staging place jumpers as shown.
 - 6 - Wires provided for Auxiliary Heat low voltage control. Wires are secured at blower.
 - 7 - When Auxiliary Heat is field installed the harness will then be connected to the auxiliary heat unit. The auxiliary heat unit will then power the blower. Refer to EAS/EAM/EAL Auxiliary Heat kit installation instructions.
 - 8 - Brown blower power wire routed through Current Transducer two times.
 - 9 - Field Connected. Refer to Installation Manual and Auxiliary Heat Instructions for Current Transducer installation.
 - 10 - Communication cable routed through Ferrite Toroid four times.
 - 11 - Compressor power cable routed through Ferrite Toroid three times.
 - 12 - Variable speed pump power wires to connect the pump to L1 and L2 on the AXB board are provided with Variable Speed Flow Center.

977842-11A 02/15/13

Wiring Schematics cont.

Aurora Variable Speed Drive/EEV Wiring

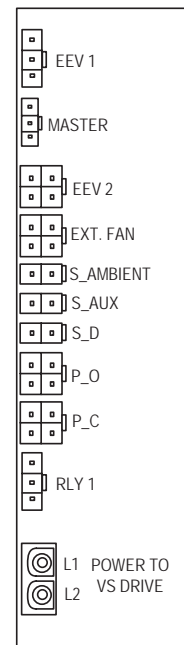
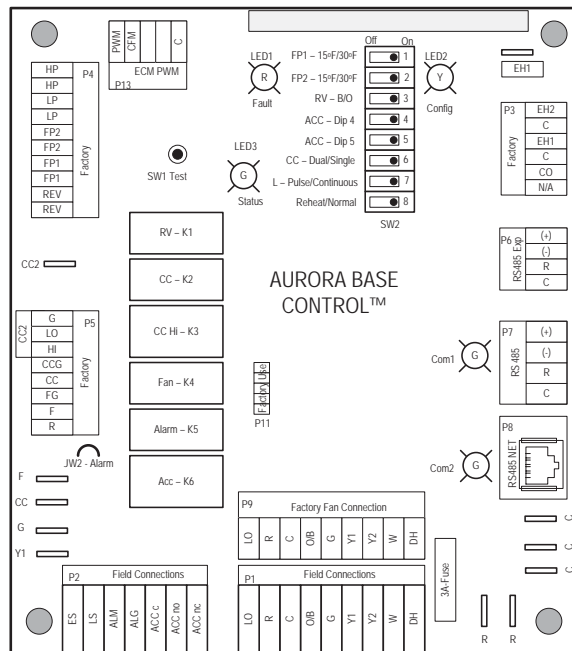
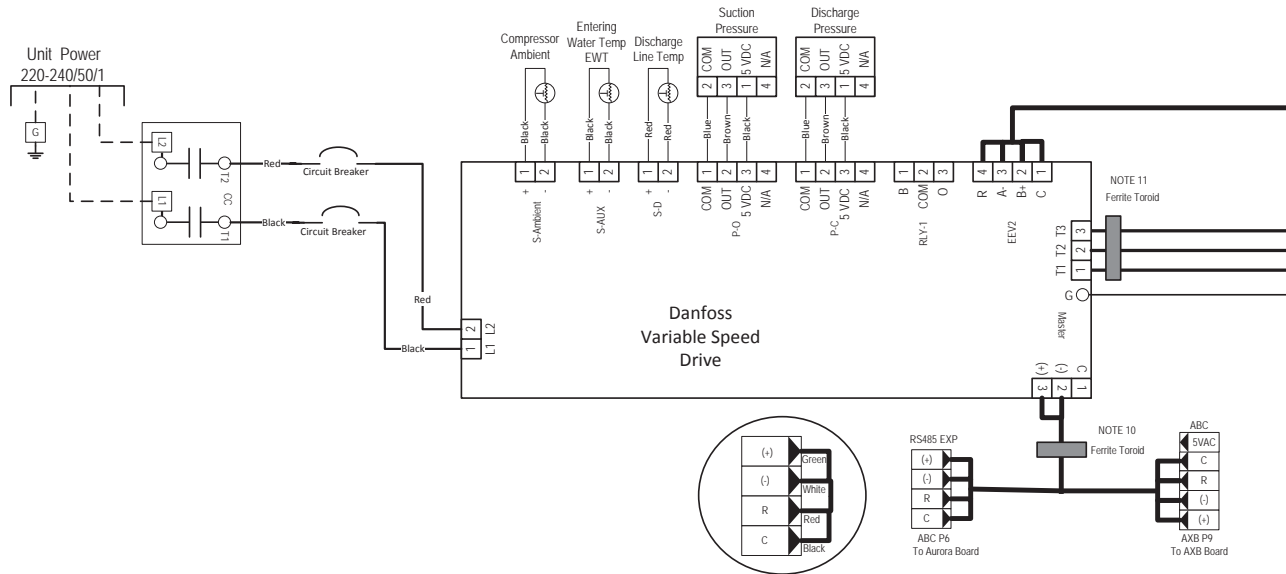

VARIABLE SPEED DRIVE END VIEWS

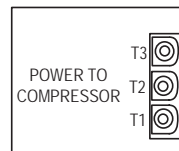
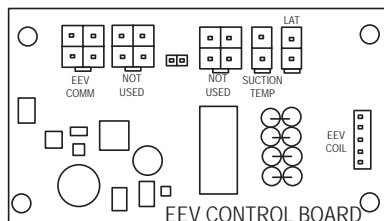

Wiring Schematics cont.

Aurora Variable Speed Drive/EEV Wiring cont.

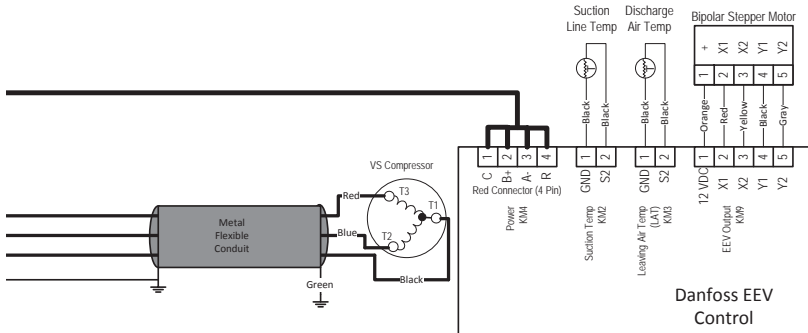

Legend

- Factory Low voltage wiring
- Factory Line voltage wiring
- - - Field low voltage wiring
- - - Field line voltage wiring
- - - Optional block
- DC Voltage PCB traces
- Junction
- Quick connect terminal
- Wire nut
- Field wire lug
- ⊥ Ground
- ⊥ Relay Contacts- N.O., N.C.
- ⊥ Fuse
- ⊡ Thermistor
- ⊡ Light emitting diode - Green
- ⊡ Relay coil
- ⊡ Capacitor w/ bleed resistor
- ⊡ Switch - Condensate overflow
- ⊡ Switch - High pressure
- ⊡ Switch - Low pressure
- ⊡ Polarized connector
- ⊡ Current Transducer (CT)

CC - Compressor Contactor
 CO - Condensate overflow sensor
 K5 - DHW pump relay
 K6 - Loop pump relay
 CR3 - PSC Fan Speed Relay
 CR4 - PSC Fan Power Relay
 CS - Compressor Solenoid
 F1 and F2 - Fuses
 HE - Heater element
 HP - High pressure switch
 ER1 to ER4 - Aux heat stage relays
 LP - Low pressure switch

PB1, PB2 - Power blocks
 PS - Power strip
 RV - Reversing Valve coil
 SW1 - DIP package 5 position AXB
 SW1 - TEST MODE ABC Board
 SW2 - DIP package 8 position ABC Board

TS - Thermal limit switch
 HWL - Hot water limit sensor
 SC - Start Contactor
 SR - Start Relay
 WCL - Water Coil Limit Sensor

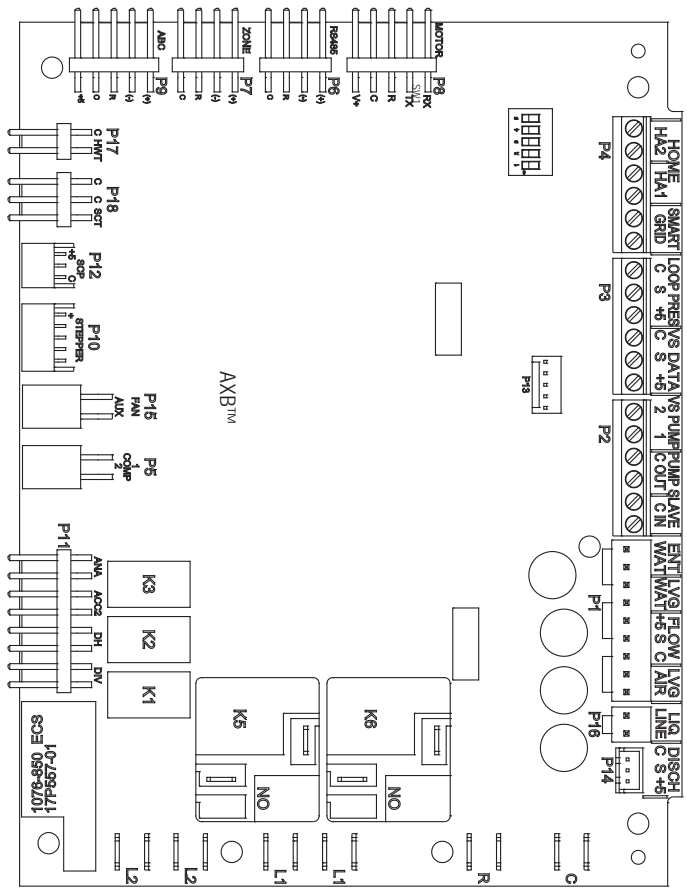

Aurora LED Flash Codes		
Slow Flash	1 second on and 1 second off	
Fast Flash	100 milliseconds on and 100 milliseconds off	
Flash Code	100 milliseconds on and 400 milliseconds off with a 2 second pause before repeating	
Fault LED (LED 1, Red)		
Normal Mode	OFF	Status LED (LED1, Green)
Input Fault Lockout	Flash Code 1	Configuration LED (LED 2, Yellow)
High Pressure Lockout	Flash Code 2	Fault LED (LED 3, Red)
Low Pressure Lockout	Flash Code 3	Configuration LED (LED 2, Yellow)
Freeze Detection - FP2	Flash Code 4	No Software Override
Freeze Detection - FP1	Flash Code 5	DIP Switch Override
Reserved	Flash Code 6	Status LED (LED 3, Green)
Condensate Overflow Lockout	Flash Code 7	Normal Mode
Over/Under Voltage Shutdown	Flash Code 8	Control is Non - Functional
Future Use	Flash Code 9	Test Mode
Compressor Monitoring	Flash Code 10	Lockout Active
Fault: FP1 and FP2 Sensor Error	Flash Code 11	Dehumidification Mode
Future Use	Flash Code 12	Future Use
Non-Critical AXB Sensor Error	Flash Code 13	Future Use
Critical AXB Sensor Error	Flash Code 14	Load Shed
Alarm - Hot Water	Flash Code 15	ESD
Fault Variable Speed Pump	Flash Code 16	Future Use
Future Use	Flash Code 17	Future Use
Fault LED (LED 1, Red) Cont.		
Non-Critical Communication Error	Flash Code 18	Safe Mode - Ambient Temperature Sensor
Fault - Critical Communication Error	Flash Code 19	Fault - Discharge Temperature Sensor
Alarm - Low Loop Pressure	Flash Code 21	Fault - Suction Pressure Sensor
Fault - Communication ECM Fan Motor Error	Flash Code 22	Fault - Condensing Pressure Sensor
Alarm - Home Automation 1	Flash Code 23	Fault - Low Supply Voltage
Alarm - Home Automation 2	Flash Code 24	Fault - Compressor Out of Envelope
Fault - EEV Error	Flash Code 25	Fault - Over Current
Derate - Drive Temperature	Flash Code 41	Fault - Over/Under Voltage
Derate - High Discharge Temperature	Flash Code 42	Fault - High Drive Temperature
Derate - Low Suction Temperature	Flash Code 43	Fault - Drive Internal Error MOC/AOC
Derate - Low Condensing Pressure	Flash Code 44	Fault - Multiple Safe Modes
Derate - High Condensing Pressure	Flash Code 45	Fault - Loss of Charge
Derate - Outer Power Limit	Flash Code 46	Safe Mode - Suction Temperature Sensor
Safe Mode - EEV (Indoor) Communication	Flash Code 47	Safe Mode - LAT Temperature Sensor
Safe Mode - EEV (Outdoor) Communication	Flash Code 48	Safe Mode - Max Operating Pressure

AXB Accessory 2 DIP Settings		
SW1-4	SW1-5	DESCRIPTION
ON	ON	Cycles with Blower
OFF	ON	Cycles with CC first stage compressor or compressor spd 1-12
ON	OFF	Cycles with CC2 second stage of compressor or comp spd 7-12
OFF	OFF	Cycles with DH from ABC board

ABC SW2 Accessory Relay		
DESCRIPTION	SW2-4	SW2-5
Cycle with Blower	ON	ON
Cycle with Compressor	OFF	OFF
Water Valve Slow Opening	ON	OFF
Cycle with Comm. T-stat Hum Cmd	OFF	ON

Engineering Guide Specifications

General

Furnish and install WaterFurnace Water Source Heat Pumps as indicated on the plans. Equipment shall be completely assembled, piped and internally wired. Capacities and characteristics as listed in the schedule and the specifications that follow. The reverse cycle heating/cooling units shall be either suspended type with horizontal air inlet and discharge or floor mounted type with horizontal air inlet and vertical upflow air discharge. Each unit shall be computer run-tested at the factory with conditioned water and operation verified to catalog data. Each unit shall be mounted on a pallet and shipped in a corrugated box or stretch-wrapped. The units shall be designed to operate with entering liquid temperature between -6.7°C and 48.9°C.

Casing and Cabinet

The cabinet shall be fabricated from heavy-gauge galvanized steel and finished with optional corrosion-resistant powder coating. This corrosion protection system shall meet the stringent 1000 hour salt spray test per ASTM B117. The interior shall be insulated with 12.7 mm thick, multi-density, cleanable aluminum foil coated glass fiber with edges sealed or tucked under flanges to prevent the introduction of glass fibers into the discharge air. Standard cabinet panel insulation must meet NFPA 90A requirements, air erosion and mold growth limits of UL-181, stringent fungal resistance test per ASTM-C1071 and ASTM G21, and shall meet zero level bacteria growth per ASTM G22. Unit insulation must meet these stringent requirements or unit(s) will not be accepted.

One (horizontal) to two (vertical) blower and two compressor compartment access panels shall be 'lift-out' removable with supply and return ductwork in place.

A duct collar shall be provided on the supply air opening. Standard size 25.4mm MERV 4 filters shall be provided with each unit. Units shall have a return air filter rack that is field convertible from 25.4mm to 50.8mm. The units shall have an insulated divider panel between the air handling section and the compressor section to minimize the transmission of compressor noise. Vertical units shall be supplied with left or right horizontal air inlet and top vertical air discharge. Horizontal units shall be supplied with left or right air inlet and side or end air discharge.

The compressor shall be double isolation mounted using selected durometer grommets to provide vibration free compressor mounting. The compressor mounting bracket shall be acoustically deadened galvanized steel to prevent vibration transmission to the cabinet.

Option: AlpinePure MERV 13 filter - A 50.8mm thick MERV 13 filter can help fulfill a credit under the LEED Rating System. Its low initial resistance promotes low energy consumption (52.3 Pa @ 1.5 m/s) and provides nearly twice the life of a standard filter (1.5 m/s vs. standard 2.54 m/s application).

Refrigerant Circuit

All units shall utilize the non-ozone depleting and low global warming potential refrigerant R-410A. All units shall contain a sealed refrigerant circuit including a hermetic motor-compressor, bidirectional thermostatic expansion valve, finned tube air-to-refrigerant heat exchanger, reversing valve, coaxial tube water-to-refrigerant heat exchanger, optional hot water generator coil, and service ports.

Compressors shall be high-efficiency single speed rotary or scroll type designed for heat pump duty and mounted on vibration isolators. The compressor shall be double isolation mounted using selected durometer grommets to provide vibration free compressor mounting.

Option: FormiShield electro-coated air coil for maximum protection against formicary corrosion.

The coaxial water-to-refrigerant heat exchanger shall be designed for low water pressure drop and constructed of a convoluted copper (cupronickel option) inner tube and a steel outer tube. Refrigerant to air heat exchangers shall utilize enhanced corrugated lanced aluminum fins and rifled copper tube construction rated to withstand 4135 kPa refrigerant working pressure. Refrigerant to water heat exchangers shall be of copper inner water tube and steel refrigerant outer tube design, rated to withstand 4135 kPa working refrigerant pressure and 3101 kPa working water pressure.

The thermostatic expansion valve shall provide proper superheat over the entire liquid temperature range with minimal "hunting." The valve shall operate bidirectionally without the use of check valves.

Option: Cupronickel refrigerant to water heat exchanger shall be of copper-nickel inner water tube and steel refrigerant outer tube design, rated to withstand 4135 kPa working refrigerant pressure and 3101 kPa working water pressure. Water lines shall also be of cupronickel construction.

Option: Hot water generator - Internal double wall vented hot water generator coil refrigerant to water heat exchangers shall be of copper inner water tube and steel refrigerant outer tube design, rated to withstand 4135 kPa working refrigerant pressure and 3101 kPa working water pressure.

Engineering Guide Specifications cont.

Blower Motor and Assembly

The blower shall be a direct drive centrifugal type with a dynamically balanced wheel. The housing and wheel shall be designed for quiet low outlet velocity operation. The blower housing shall be removable from the unit without disconnecting the supply air ductwork for servicing of the blower motor. The blower motor shall be isolated from the housing by rubber grommets. The motor shall be permanently lubricated and have thermostatic overload protection.

Electrical

A control box shall be located within the unit compressor compartment and shall contain a 50VA or 75VA transformer, 24 volt activated, 2 pole compressor contactor, terminal block for thermostat wiring and solid-state controller for complete unit operation. Electromechanical operation WILL NOT be accepted. Units shall be name-plated for use with time delay fuses or HACR circuit breakers. Unit controls shall be 24 volt and provide heating or cooling as required by the remote thermostat/sensor.

An Aurora microprocessor-based controller that interfaces with a multi-stage electronic thermostat to monitor and control unit operation shall be provided. The control shall provide operational sequencing, blower speed control, high and low pressure switch monitoring, freeze detection, condensate overflow sensing, lockout mode control, LED status and fault indicators, fault memory, field selectable options and accessory output. The control shall provide fault retry three times before locking out to limit nuisance trips.

A detachable terminal block with screw terminals will be provided for field control wiring. All units shall have knockouts for entrance of low and line voltage wiring. The blower motor and control box shall be harness plug wired for easy removal.

Piping

Supply and return water connections shall be FPT copper fittings fixed to the corner post, which eliminate the need for backup pipe wrenches.

With vertical units, the condensate connection shall be a 19.1 mm PVC socket with internally-trapped hose that can be routed to front or side corner post locations.

Hanger Kit

(included with horizontal units only - field installed)

The hanger kit shall consist of galvanized steel brackets, bolts, lock washers, and isolators and shall be designed to fasten to the unit bottom panel for suspension from 3/8 in. threaded rods. Unit sizes 005-015 shall require four brackets and unit size 017 shall require five brackets. Brackets shall not inhibit filter removal in any way.

Options and Accessories

Cupronickel Heat Exchanger

An optional cupronickel water-to-refrigerant heat exchanger shall be provided.

Hot Water Generator

An optional ThermaShield coated heat reclaiming hot water generator coil of vented double-wall copper construction suitable for potable water shall be provided. The coil and hot water circulating pump shall be factory mounted inside the unit with integral electronic high limit temperature monitoring and external on/off switch. Hot water set point is selectable through the AID Tool.

AlpinePure 411-Rack 4 in. Pleated Filter Accessory

A 4 in. [102 mm] thick MERV 11 filter and filter rack shall be provided in lieu of the standard filter and rack.

Thermostat (field-installed)

A communicating auto-changeover electronic digital thermostat shall be provided. The thermostat shall offer variable speed heating and cooling staging with precise temperature control. An OFF-HEAT-AUTO-COOL-EMERG system switch, OFF-AUTO-INTERMITTENT blower switch, and indicating display shall be provided. The thermostat shall display in °F or °C. The thermostat shall provide real time energy consumption data of the unit.

Color Touchscreen Thermostat (field-installed)

A color touchscreen communicating auto-changeover electronic digital thermostat shall be provided. The thermostat shall offer variable speed heating and cooling staging with precise temperature control. An OFF-HEAT-AUTO-COOL-EMERG system switch, OFF-AUTO-INTERMITTENT blower switch, and indicating display shall be provided. The thermostat shall display in °F or °C. The thermostat shall provide real time and historical energy consumption data of the unit.

Electronic Air Cleaner (field-installed)

A 25mm electronic air cleaner, cleanable 97% efficiency at 0.3 microns and larger, shall be provided in lieu of the standard throwaway filter. The initial pressure drop across the filter shall not exceed 0.05 kPa at 1.5 m/s force velocity.

Electrostatic Air Cleaner (field-installed)

A 25mm electrostatic air cleaner, cleanable 90% efficiency, shall be provided in lieu of the standard throwaway filter. The initial pressure drop across the filter shall not exceed 0.04 kPa at 1.5 m/s force velocity.

Engineering Guide Specifications cont.

AlpinePure 411-Rack 102mm Pleated Filter Accessory

A 102mm thick MERV 11 filter and filter rack shall be provided in lieu of the standard filter and rack.

AlpinePure MERV 13 Filter (field-installed)

A 50mm thick MERV 13 filter shall be provided in lieu of the standard filter and fits the factory filter rack. The filter maintains MERV 13 rating in full ASHRAE 52.2 independent testing as required for LEED® certification. Helps fulfill a full credit under the LEED rating system.

AlpinePure HRV/ERV (field installed)

A self-contained unit shall provide removal of stale air while replenishing the structure with an equal amount of fresh, clean air. The incoming and exhaust air streams shall be completely separate through the exchanger. The Heat Recovery Ventilator (HRV) shall transfer sensible heat from the stale exhaust air to the fresh incoming air with a Sensible Efficiency up to 79%. The HRV shall be equipped with a Defrost Mode. The Energy Recovery Ventilator (ERV) shall transfer sensible heat as well as latent heat with a Total Efficiency of 50%. The ERV shall be designed for use in warm humid areas with heavy air conditioning use. The ERV shall not be recommended for use in areas where the temperature drops below -4°C for more than five days. The ERV shall not be equipped with a Defrost Mode.

AlpinePure HEPA Filter (field-installed)

For the ultimate in air filtration, the AlpinePure Series HEPA filter captures 99.97% of all particles down to 0.30 microns in size.

AlpinePure Drain Pan Treatment (field-installed)

Provides dependable, sustained time-release protection from slime build-up and foul smelling odors in the drain pan. Also adds a light, pleasant scent to the air.

Earth Loop Flow Center (field-installed)

A self-contained module shall provide all liquid flow, fill and connection requirements for ground source closed loop systems up to 76 L/s. The pumps shall be wired to a power block located in the nearest unit. The heat pump units shall contain low voltage pump slaving control so that two units may share one flow center.

Auxiliary Heater (field-installed)

An electric resistance heater shall provide supplemental and/or emergency heating capability. Vertical units shall have the control panel and resistance heater coil assembly mounted internally. For horizontal units, the control panel shall be mounted internally while the resistance heater coil assembly shall be mounted externally. A low voltage plug shall be provided in each unit for quick auxiliary heat connection. The heater shall operate in sequenced stages as controlled by the unit's microprocessor. The heater shall feed line voltage power to the unit blower and transformer to provide emergency heat capability in the event of an open compressor circuit breaker.

Revision Guide

Pages:	Description:	Date:	By:
All	First Published	05 Sept 2013	DS
6, 34-39	Updated data tables EER values to be in W/W units	18 Nov 2014	MA
14	Corrected temperatures in "Active- Dehumidification" section	18 Nov 2014	MA



Manufactured by
WaterFurnace International, Inc.
9000 Conservation Way
Fort Wayne, IN 46809 USA
www.waterfurnace.com

